



SERIE E36 HS



MINIATURE BLIND HOLLOW SHAFT ABSOLUTE SINGLETURN ENCODER

- Singleturn resolution up to 13 bits
- Magnetic technology
- External diameter 36.5 mm
- Blind hollow shaft \varnothing 6 mm or 8 mm
- Protection class IP64 according to DIN EN 60529
- Connection by cable (other cable length available)



Magnetic Encoder	Absolute Encoder	Miniature Encoder	Vibration and shock resistant	IP 64	Temperature range -40°C	Express Delivery

Setscrew / Flexible flange (90.1037)

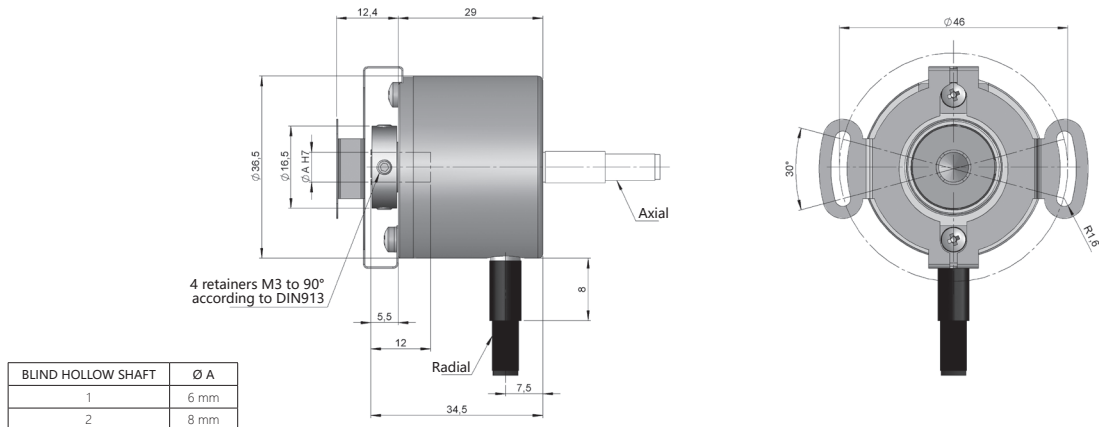

Setscrew / Flexible flange (90.1111)

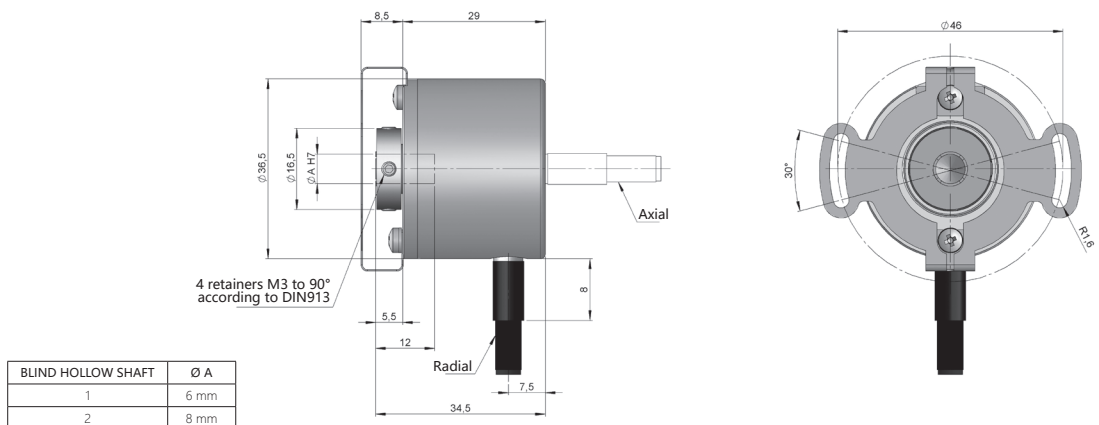

SERIE E36 HS

MINIATURE BLIND HOLLOW SHAFT ABSOLUTE SINGLETURN ENCODER



REFERENCE

Reference example: E36HS-BIS-11211-12

Serie	Interface	Anti-rotation system	Blind-Hollow shaft	Connection	Code	Power Supply / Electronic output	Singleturn resolution	Special customer
E36HS -	BIS -	<input type="checkbox"/>	<input type="checkbox"/>	<input type="checkbox"/>	<input type="checkbox"/>	<input type="checkbox"/> -	<input type="checkbox"/> <input type="checkbox"/>	<input type="checkbox"/> <input type="checkbox"/> <input type="checkbox"/> <input type="checkbox"/>
	BIS. BISS-C	1. Flexible flange (90.1037) 2. Flexible flange (90.1111) (*)	1. Ø 6 mm 2. Ø 8 mm	1. Axial cable 2. Radial cable 3. Radial M12 8p CCW	1. Binary CW 2. Binary CCW	1. 4,75...30 VDC / RS422	09. 9 bits 10. 10 bits 11. 11 bits 12. 12 bits 13. 13 bits	

Order your reference
Step file 3D

info@encoderhohner.com
service available in 24 h

(*) Anti-rotation system type 1 (Flexible flange 90.1037) and 2 (Flexible flange 90.1111) supplied assembled.

MECHANICAL SPECIFICATIONS

Materials	Cover: Aluminium Housing: Aluminium Shaft: Stainless Steel
Bearings	Ballraces
Bearings lifetime	1x10 ¹⁰ rev.
Housing fixing	Flexible flange (included)
Permitted misalignment	±0.3 mm axial, ±0.2 mm radial (90.1037) ±0.2 mm axial, ±0.1 mm radial (90.1111)
Shaft fixing	Setscrew
Blind hollow shaft diameter	6 mm or 8 mm
Maximum number of revolutions permitted mechanically	6000 rpm - Standard 10000 rpm - Upon request 12000 rpm (≤ 12 bits) - Upon request
Protection against dust and splashes according to DIN EN 60529	IP64
Rotor inertia moment	10 gcm ²
Starting torque at 20°C (68°F)	≤ 0.01 Nm
Maximum load permitted on axial shaft	20 N
Maximum load permitted on radial shaft	40 N
Weight aprox.	0.08 Kg
Operating temperature range	-40°C to +105°C
Vibration according to DIN EN 60068-2-6	100 m/s ² (10Hz...2000Hz)
Shock according to DIN EN 60068-2-27	1000 m/s ² (6ms)
Axial or radial connection	2 meters cable (other cable lengths available on order)

SERIE E36 HS

MINIATURE BLIND HOLLOW SHAFT ABSOLUTE SINGLETURN ENCODER



ELECTRICAL SPECIFICATIONS

Interface



Electronic output	RS422
Power supply (VDC)	4.75...30 VDC
Consumption	≤ 100 mA
Code	Binary
Protocol	BISS-C
Singleturn resolution	up to 13 bits
Absolute accuracy	±0.35°
Relative accuracy	±1.5 LSB
Max. load capability / channel	±20 mA
“Low” signal level	< 0.8 VDC
“High” signal level	2 ... 5.5 VDC
Frequency	50 kHz...10 MHz
Short circuit protection	Yes
Protection polarity inversion	Yes

CONNECTION



	Cable 8x0,14 mm ² 95.0008052	Connector M12 8P CCW
GND	White (WH)	1
+UB	Brown (BN)	2
DT+	Yellow (YE)	5
DT-	Pink (PK)	6
CK+	Green (GN)	3
CK-	Grey (GY)	4
PRESET (*)	Red (RD)	7
DIR (**)	Blue (BU)	8
Case	Shield	Case

(*) Apply a 4.75...30 VDC pulse (more than 1 ms) to set the encoder to Zero and reboot the encoder (turn off and then turn on the power supply).

(**) Connect to 4.75...30 VDC to change direction from default. If this input is not used, it should be connected to GND in order to avoid interferences. The encoder must be always rebooted (turn off and then turn on the power supply) after switching.

CONNECTION DIMENSIONS

Female connector not included

Connection 3

Radial M12 8p
male panel
counter clockwise

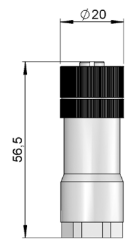
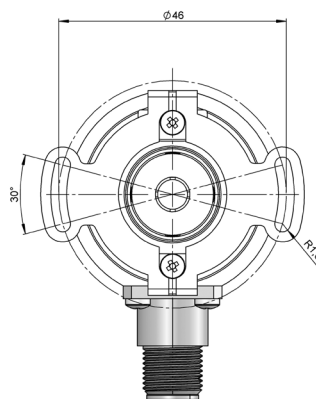
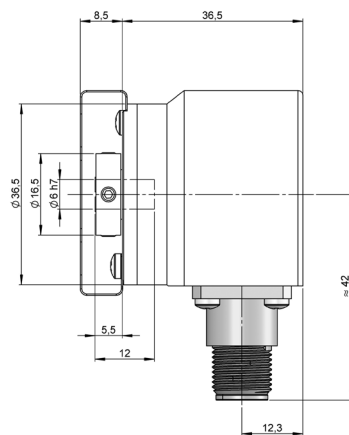

Female connector
95.0007152



Pre-assembled cable
89.003.02.000.XX
Length in meters

SERIE E36 HS

MINIATURE BLIND HOLLOW SHAFT ABSOLUTE SINGLETURN ENCODER



ANTI-ROTATION SYSTEMS DIMENSIONS

Flexible flange
90.1036

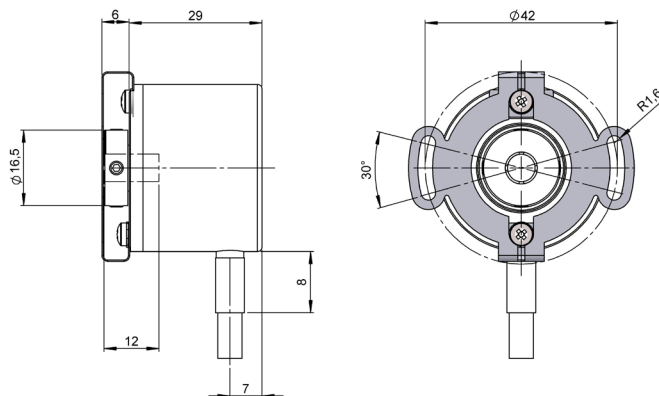

90.1036

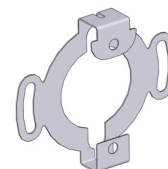

Flexible flange
90.1083

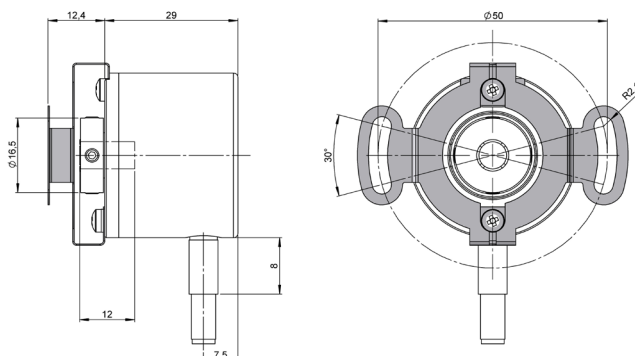

90.1083

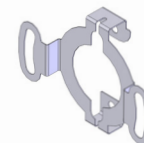

Flexible flange
93.0102087

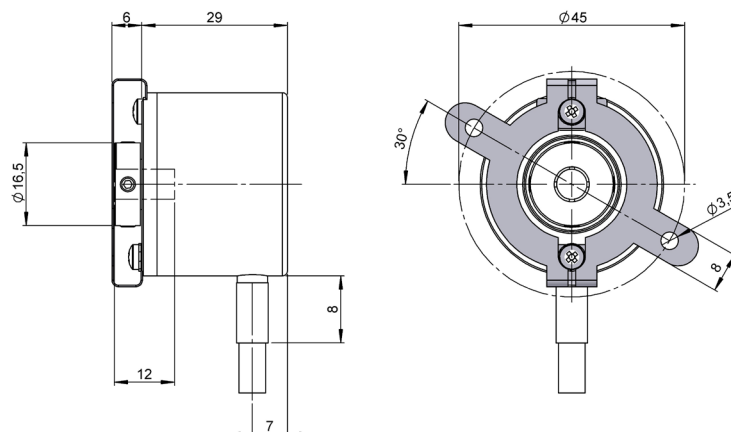

93.0102087

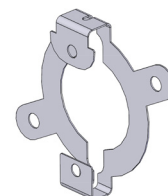

SERIE E36 HS

MINIATURE BLIND HOLLOW SHAFT ABSOLUTE SINGLETURN ENCODER



Flexible flange
93.0102145

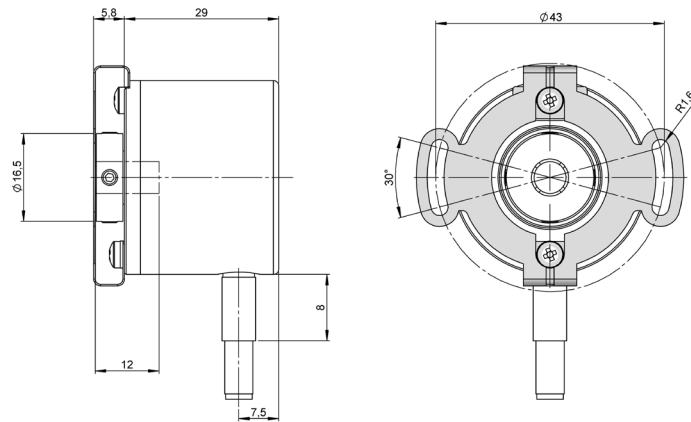

93.0102145



Flexible flange
93.0102150

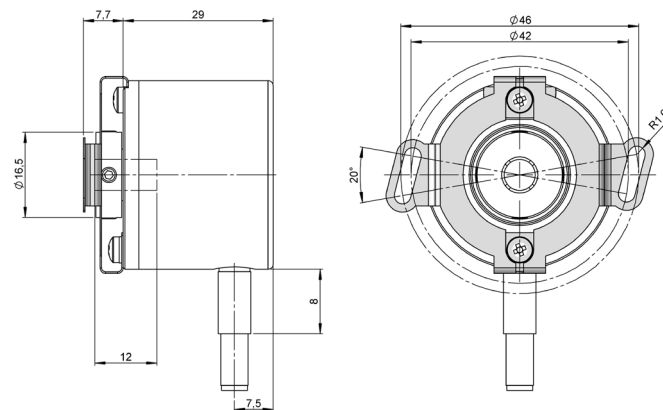

93.0102150

