

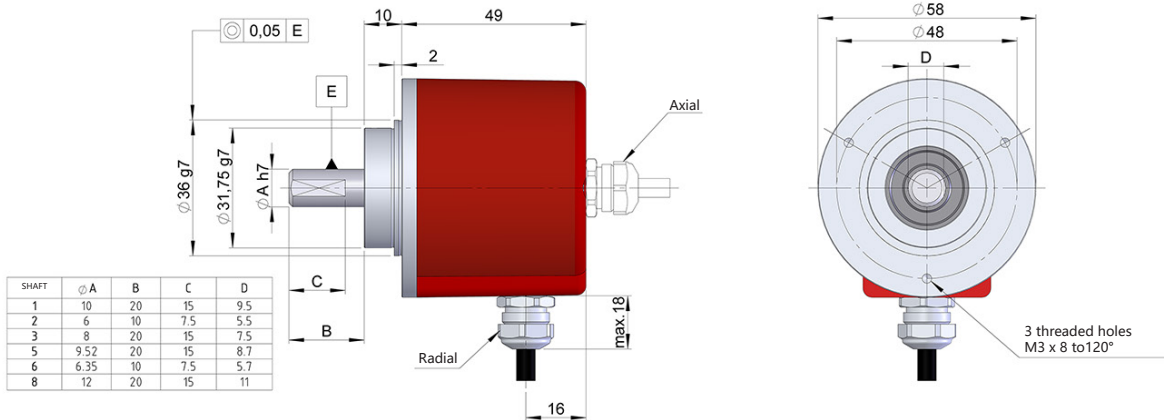

SERIE 10

HIGH RESOLUTION INCREMENTAL SOLID SHAFT ENCODER FOR INDUSTRIAL APPLICATIONS

- Resolution up to 50000 pulses per turn
- External diameter 58 mm
- Shaft from Ø 6 to 12 mm
- Protection class IP67 according to DIN EN 60529
- Highly flexible flanges and different configurations
- Executions mechanical, electronic and special optics forms available on request
- Connection by cable or industrial connector (other cable lengths available)



Drawing connection type 3/8, without flange

REFERENCE

Reference example: 10-11639-1024

Serie	Solid shaft	Flange	Output signals	Connection	Power Supply / Electronic output	Pulses number	Special customer
10/10A -	<input type="checkbox"/>	<input type="checkbox"/>	<input type="checkbox"/>	<input type="checkbox"/>	<input type="checkbox"/> -	<input type="checkbox"/> <input type="checkbox"/> <input type="checkbox"/> <input type="checkbox"/> <input type="checkbox"/>	<input type="checkbox"/> <input type="checkbox"/> <input type="checkbox"/> <input type="checkbox"/>
10. IP 65	1. Ø 10x20 mm	1. None	1. A	1. Radial 4p	0. 11...30 VDC / NPN Open collector 11..30 VDC	(*)	AT00. -40°C
10A. IP 67	2. Ø 6x10 mm	2. 90.1002	2. AB	3. Radial cable	6. 11...30 VDC / RS422 5 VDC (compatible TTL)		
(**)	3. Ø 8x20 mm	3. 90.1003	3. AB, \bar{Z}	4. Radial Mil 7p	7. 5 VDC / RS422 5 VDC (compatible TTL)		
	5. Ø 9.52x20 mm	4. 90.1004	5. AB, $\bar{A}\bar{B}$	5. Radial M23 12p	9. 11...30 VDC / Line driver differential Push-Pull 11..30 VDC		
	6. Ø 6.35x10 mm	5. 90.1005	6. ABZ, $\bar{A}\bar{B}\bar{Z}$	6. Axial 4p			
	8. Ø 12x20 mm	7. 90.1006 (***)	9. ABZ	8. Axial cable			
				9. Axial Mil 7p			
				0. Axial M23 12p			
				M. Radial Mil 10p			
				N. Axial Mil 10p			
				L. Radial M12 8p			
				K. Axial M12 8p			

Order your reference Step file 3D

info@encoderhohner.com
service available in 24 h

(*) 10000 to 50000 pulses with interpolation. Available 10000 direct optical pulses without interpolating upon request.

(**) The option 10A is only available with shaft type 1, and cable connection output (3/8) or connection type (L/K).

(***) Flange mounting included in delivery of the encoder.



SERIE 10

HIGH RESOLUTION INCREMENTAL SOLID SHAFT ENCODER FOR INDUSTRIAL APPLICATIONS

MECHANICAL SPECIFICATIONS

Materials	Cover: Aluminium Housing: Aluminium Shaft: Stainless Steel
Bearings	Ballraces
Bearings lifetime	1x10 ¹⁰ rev.
Shaft diameter	6, 6.35, 8, 9.52, 10 or 12 mm
Maximum number of revolutions permitted mechanically	≤ 6 000 rpm
Protection against dust and splashes according to DIN EN 60529	IP65 - Standard IP67 - Option 10A
Rotor inertia moment	30 gcm ²
Starting torque at 20°C (68°F)	≤ 0.02 Nm - Standard ≤ 0.03 Nm - Option 10A
Maximum load permitted on axial shaft	≤ 40 N
Maximum load permitted on radial shaft	≤ 80 N
Weight aprox.	0.5 Kg
Operating temperature range	-20°C to +80°C - Standard -40°C to +80°C - Special Customer AT00
Vibration according to DIN EN 60068-2-6	100 m/s ² (10Hz...2 000Hz)
Shock according to DIN EN 60068-2-27	1000 m/s ² (6ms)
Maximum pulses per turn	≤ 50000
Axial or radial connection	2 meters cable or industrial connector (different models available, other cable lengths available on order) Female connector not included

OUTPUT SIGNALS

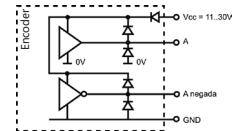
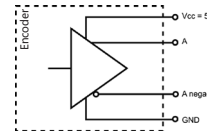
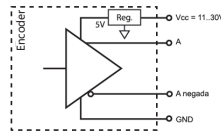
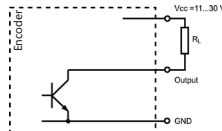

OUTPUT CIRCUIT	NPN Open Collector	RS422 (TTL compatible)	RS422 (TTL compatible)	Push-Pull Differential
Reference code	0	6	7	9
Power supply	11...30 VDC	11...30 VDC	5 VDC ±10%	11...30 VDC
Output voltage	11...30 VDC	5 VDC	5 VDC	11...30 VDC
Consumption	40 mA	Typical: 80 mA Max: 160 mA	Typical: 70 mA Max: 150 mA	Typical: 45 mA Max: 150 mA
Max. load capability / channel	40 mA	±20 mA	±20 mA	±30 mA
Length of cable allowed	50 m (24 VDC)	1200 m	1200 m	100 m
“Low” signal level	VOL < 0.4 VDC (24 VDC)	VOL < 0.5 VDC	VOL < 0.5 VDC	VOL < 2.5 VDC
“High” signal level	VOH > 2.2 VDC (24 VDC)	VOH > 2.5 VDC	VOH > 2.5 VDC	VOH > VCC – 3 VDC
Frequency	100 kHz	300 kHz	300 kHz	200 kHz
Short circuit protection	Not permanent	Yes	Yes	Yes
Protection polarity inversion	Yes	Yes	Not permanent	Yes

Channel B leads (90° electric) channel A, view from the shaft, shaft rotating clockwise

SERIE 10

HIGH RESOLUTION INCREMENTAL SOLID SHAFT ENCODER FOR INDUSTRIAL APPLICATIONS

CONNECTION

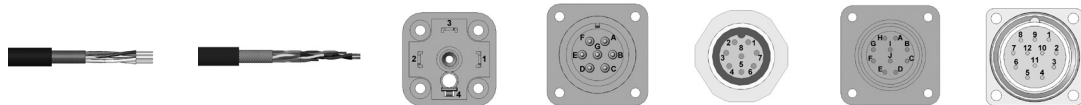

	Cable 2x2x0.14+1x0.14 95.0008002	Cable 3x2x0.14+2x0.34 95.0008003 (*)	Connector DIN 43650 4p	Connector Mil 7p CW	Connector M12 8p CCW	Connector Mil 10p CW	Connector M23 12p CW
GND	Yellow (YE)	Black (BK)	1	A	1	A	1
+UB	White (WH)	Red (RD)	2	B	2	B	2
A	Brown (BN)	Yellow (YE)	3	C	3	C	3
B	Green (GN)	Green (GN)	4	D	4	D	4
\bar{A}	-	Brown (BN)	-	E	5	E	5
\bar{B}	-	Blue (BU)	-	F	6	F	6
Z	Grey (GY)	Grey (GY)	-	G	7	G	7
\bar{Z}	Grey (GY)	Orange (OG)	-	G	8	H	8
Case	Shield	Shield	-	Case	Case	Case	Case

(*) Cable 3x2x0.14+2x0.34 only for encoders with inverted signals.

ACCESSORIES EXAMPLES

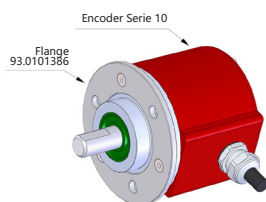
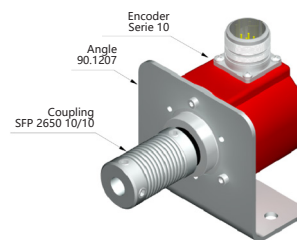
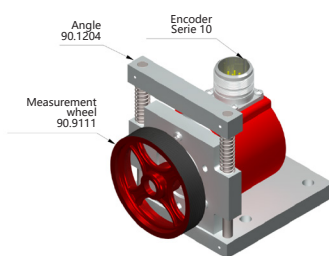
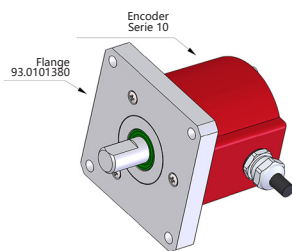

This flange requires a special customer code in the reference AB09

All the accessories available in the section "MOUNTING ACCESSORIES".

SERIE 10

HIGH RESOLUTION INCREMENTAL SOLID SHAFT ENCODER FOR INDUSTRIAL APPLICATIONS

FLANGE DIMENSIONS

Flange mounting included

Flange 2
90.1002

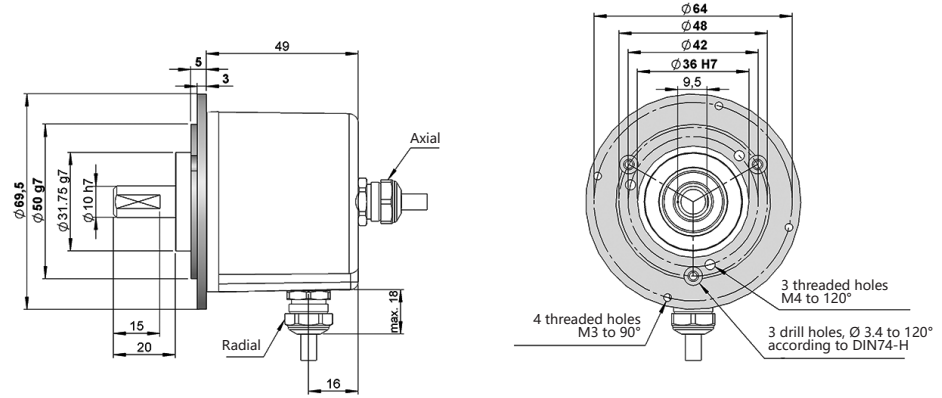

Flange 3
90.1003

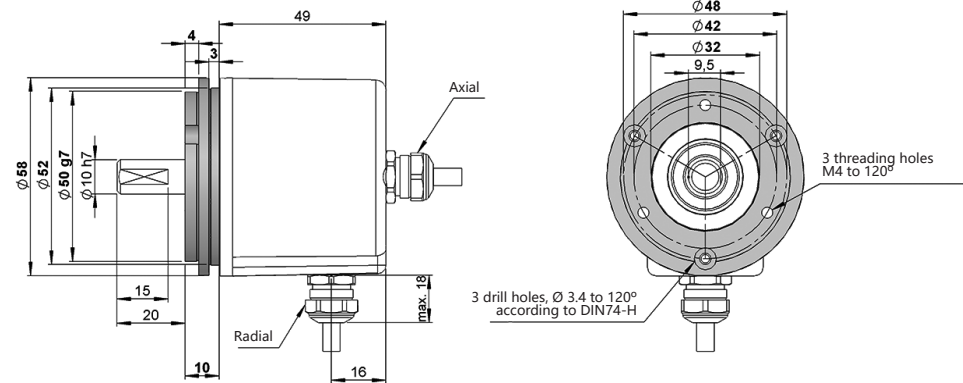

Flange 4
90.1004

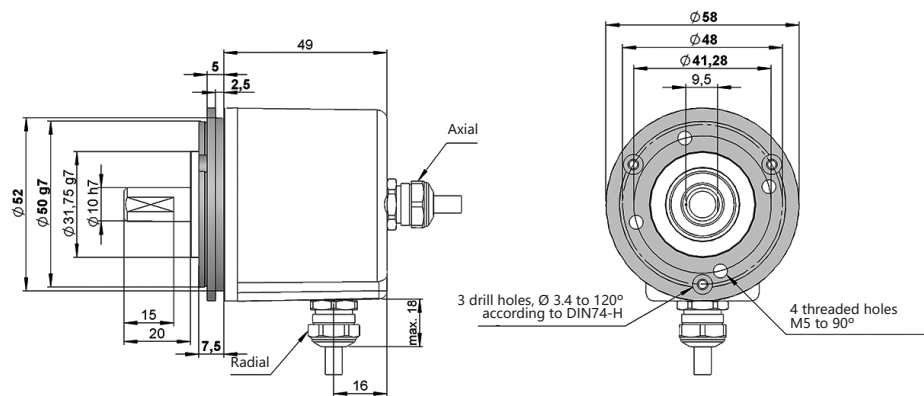

SERIE 10

HIGH RESOLUTION INCREMENTAL SOLID SHAFT ENCODER FOR INDUSTRIAL APPLICATIONS

Flange 5 90.1005

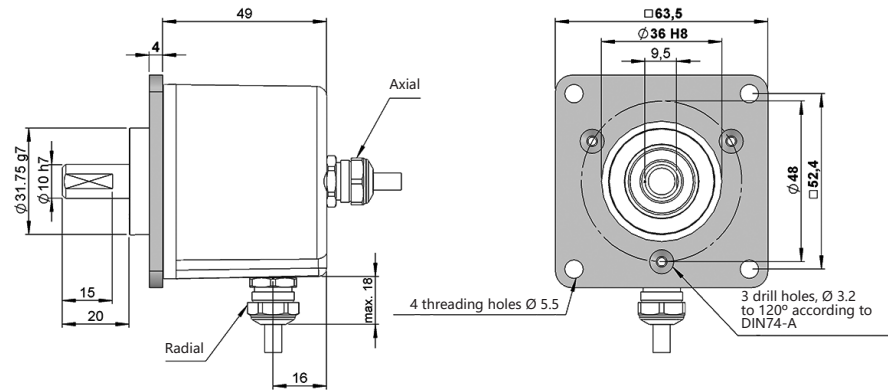

Flange 7 90.1006

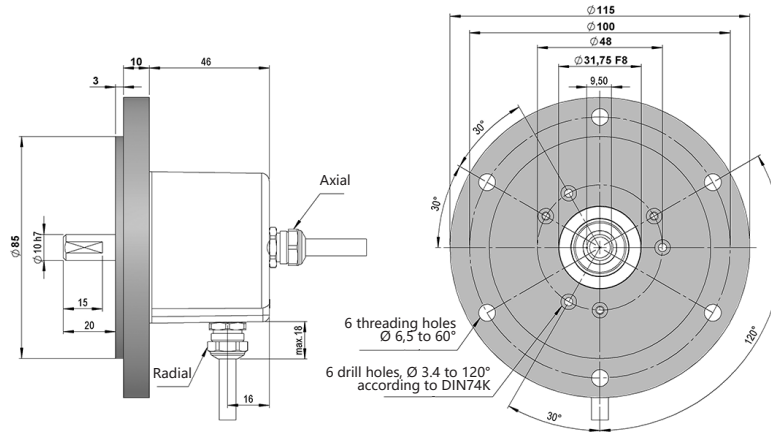

CONNECTION DIMENSIONS

Female connector not included

Connection 1

Radial
DIN 43650 4p
male panel

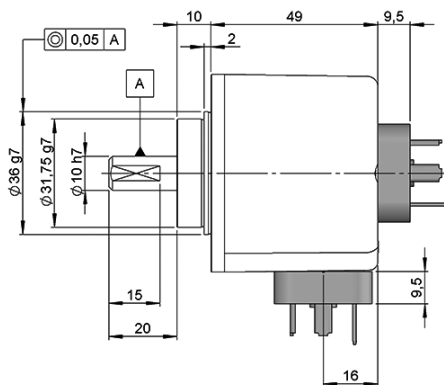

Connection 6

Axial
DIN 43650 4p
male panel

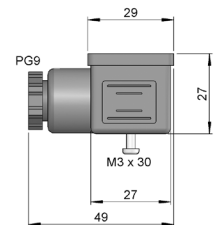
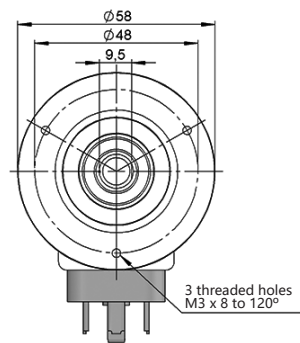

Female connector
95.0007011

Pre-assembled cable
89.001.01.000.XX
Length in meters

SERIE 10

HIGH RESOLUTION INCREMENTAL SOLID SHAFT ENCODER FOR INDUSTRIAL APPLICATIONS

Connection 4

Radial
Mil 7p
male panel
clockwise

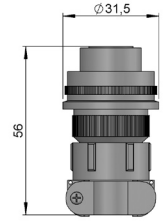
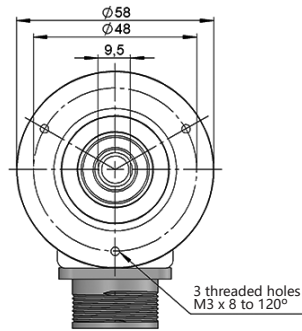
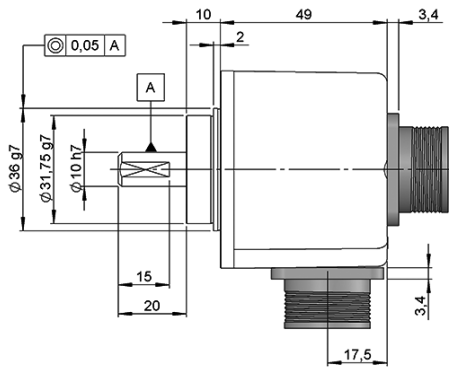

Female connector
90.9507H



Pre-assembled cable

Without inverted signals: 89.002.01.019.XX

With inverted signals: 89.002.02.000.XX

Length in meters

Connection 9

Axial
Mil 7p
male panel
clockwise



Female connector
90.9507H

Pre-assembled cable

Without inverted signals: 89.002.01.019.XX

With inverted signals: 89.002.02.000.XX

Length in meters

Connection 5

Radial
M23 12p
male panel
clockwise

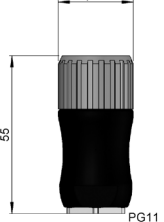
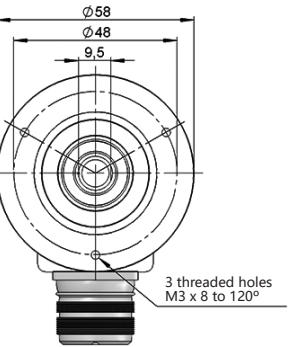
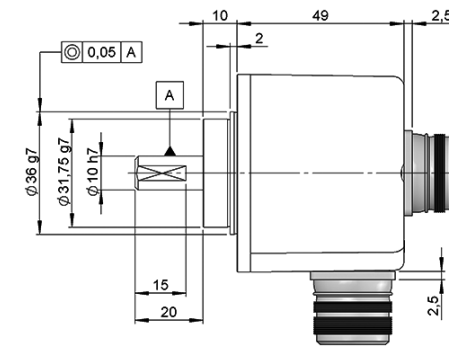

Female connector
95.0007131



Pre-assembled cable

Without inverted signals: 89.005.01.019.XX

With inverted signals: 89.005.02.000.XX

Length in meters

Connection 0

Axial
M23 12p
male panel
clockwise

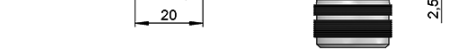

Female connector
95.0007131

Pre-assembled cable

Without inverted signals: 89.005.01.019.XX

With inverted signals: 89.005.02.000.XX

Length in meters

Connection M

Radial
Mil 10p
male panel
clockwise

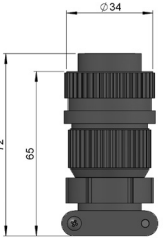
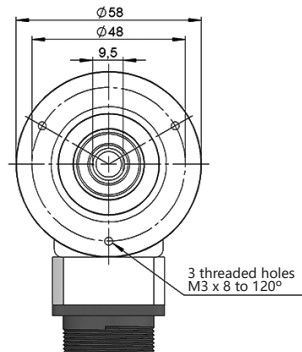
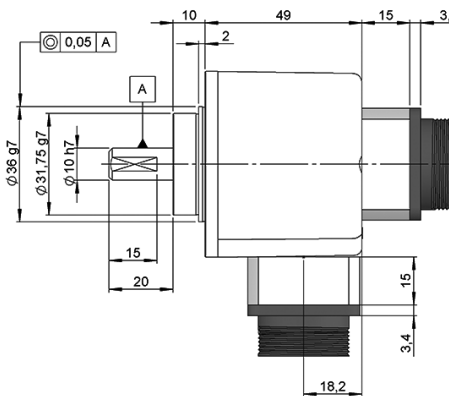

Female connector
90.9510H



Pre-assembled cable

Without inverted signals: 89.004.01.000.XX

With inverted signals: 89.004.02.000.XX

Length in meters

Connection N

Axial
Mil 10p
male panel
clockwise



Female connector
90.9510H

Pre-assembled cable

Without inverted signals: 89.004.01.000.XX

With inverted signals: 89.004.02.000.XX

Length in meters

SERIE 10

HIGH RESOLUTION INCREMENTAL SOLID SHAFT ENCODER FOR INDUSTRIAL APPLICATIONS

Connection L

Radial
M12 8p
male panel
counter clockwise

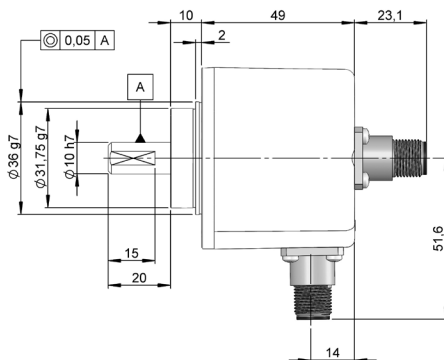

Connection K

Axial
M12 8p
male panel
counter clockwise

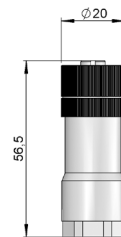
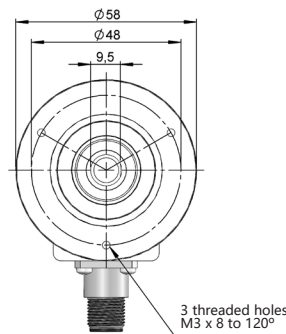

Female connector
95.0007152



Pre-assembled cable

Without inverted signals: 89.003.01.000.XX
With inverted signals: 89.003.02.000.XX
Length in meters