

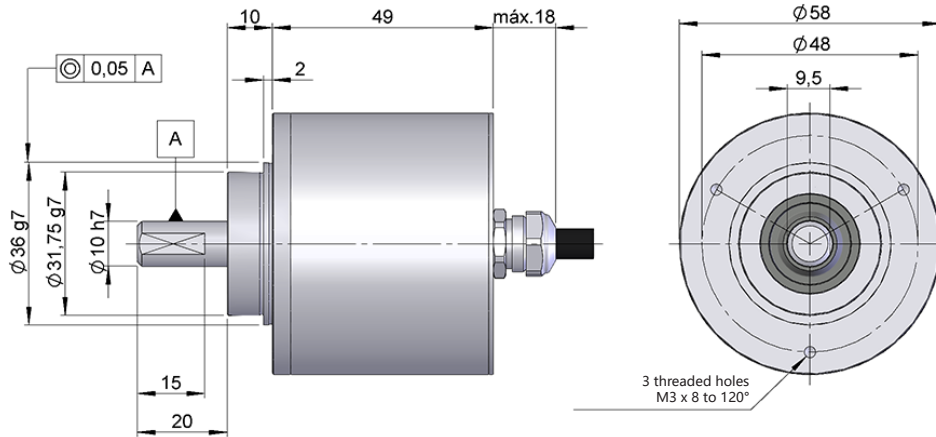

SERIE 10I INOX

HIGH RESOLUTION INCREMENTAL SOLID SHAFT ENCODER FOR HEAVY DUTY INDUSTRIAL APPLICATIONS

- Resolution up to 50000 pulses per turn
- External diameter 58 mm
- Shaft Ø 10 mm
- Protection class IP67 according to DIN EN 60529
- Executions mechanical, electronic and special optics forms available on request
- Connection by cable (other cable length available)



Drawing shaft type 1, connection type 8, without flange

REFERENCE

Reference example: 10I-11689-1024

Serie	Solid shaft	Flange	Output signals	Connection	Power Supply / Electronic output	Pulses number	Special customer
10I -	<input type="checkbox"/>	<input type="checkbox"/>	<input type="checkbox"/>	<input type="checkbox"/>	<input type="checkbox"/>	<input type="checkbox"/> <input type="checkbox"/> <input type="checkbox"/> <input type="checkbox"/> <input type="checkbox"/>	<input type="checkbox"/> <input type="checkbox"/> <input type="checkbox"/> <input type="checkbox"/> <input type="checkbox"/>
10I. Stainless Steel	1. Ø 10x20 mm	1. None	1. A 2. AB 3. AB, \bar{Z} 5. AB, \overline{AB} 6. ABZ, \overline{ABZ} 9. ABZ	8. Axial cable	0. 11...30 VDC / NPN Open collector 11...30 VDC 6. 11...30 VDC / RS422 5 VDC (compatible TTL) 7. 5 VDC / RS422 5 VDC (compatible TTL) 9. 11...30 VDC / Line driver differential Push-Pull 11...30 VDC	(*)	AT00. -40°C

Order your reference Step file 3D

info@encoderhohner.com

service available in 24 h

(*) 10000 to 50000 pulses with interpolation. Available 10000 direct optical pulses without interpolating upon request.



SERIE 10I INOX

HIGH RESOLUTION INCREMENTAL SOLID SHAFT ENCODER FOR HEAVY DUTY INDUSTRIAL APPLICATIONS

MECHANICAL SPECIFICATIONS

Materials	Cover: Stainless Steel AISI304 Housing: Stainless Steel AISI304 Shaft: Stainless Steel AISI304
Bearings	Ballraces
Bearings lifetime	1x10 ¹⁰ rev.
Maximum number of revolutions permitted mechanically	6000 rpm
Protection against dust and splashes according to DIN EN 60529	IP67
Rotor inertia moment	30 gcm ²
Starting torque at 20°C (68°F)	≤ 0.02 Nm
Maximum load permitted on axial shaft	40 N
Maximum load permitted on radial shaft	80 N
Weight aprox.	0.5 Kg
Operating temperature range	-20°C to +80°C - Standard -40°C to +80°C - Special Customer AT00
Vibration according to DIN EN 60068-2-6	100 m/s ² (10Hz...2000Hz)
Shock according to DIN EN 60068-2-27	1000 m/s ² (6ms)
Maximum pulses per turn	50000
Axial connection	2 meters cable (other cable lengths available or connector mounted at the end of the cable, upon request)

OUTPUT SIGNALS

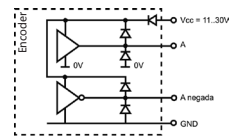
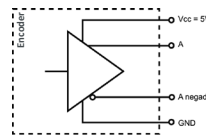
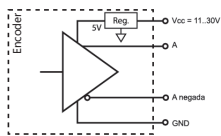
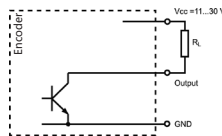

OUTPUT CIRCUIT	NPN Open Collector	RS422 (TTL compatible)	RS422 (TTL compatible)	Push-Pull Differential
Reference code	0	6	7	9
Power supply	11...30 VDC	11...30 VDC	5 VDC ±5%	11...30 VDC
Output voltage	11...30 VDC	5 VDC	5 VDC	11...30 VDC
Consumption	40 mA	Typical: 80 mA Max: 160 mA	Typical: 70 mA Max: 150 mA	Typical: 45 mA Max: 150 mA
Max. load capability / channel	40 mA	±20 mA	±20 mA	±30 mA
Length of cable allowed	50 m (24 VDC)	1200 m	1200 m	100 m
“Low” signal level	VOL < 0.4 VDC (24 VDC)	VOL < 0.5 VDC	VOL < 0.5 VDC	VOL < 2.5 VDC
“High” signal level	VOH > 22 VDC (24 VDC)	VOH > 2.5 VDC	VOH > 2.5 VDC	VOH > VCC – 3 VDC
Frequency	100 kHz	300 kHz	300 kHz	200 kHz
Short circuit protection	Not permanent	Yes	Yes	Yes
Protection polarity inversion	Yes	Yes	No	Yes

Channel B leads (90° electric) channel A, view from the shaft, shaft rotating clockwise.

SERIE 10I INOX

HIGH RESOLUTION INCREMENTAL SOLID SHAFT ENCODER FOR HEAVY DUTY INDUSTRIAL APPLICATIONS

CONNECTION



	Cable 2x2x0.14+1x0.14 95.0008002	Cable 3x2x0.14+2x0.34 95.0008003 (*)
GND	Yellow (YE)	Black (BK)
+UB	White (WH)	Red (RD)
A	Brown (BN)	Yellow (YE)
B	Green (GN)	Green (GN)
\bar{A}	-	Brown (BN)
\bar{B}	-	Blue (BU)
Z	Grey (GY)	Grey (GY)
\bar{Z}	Grey (GY)	Orange (OG)
Case	Shield	Shield

(*) Cable 3x2x0.14+2x0.34 only for encoders with inverted signals.

ACCESSORIES EXAMPLES

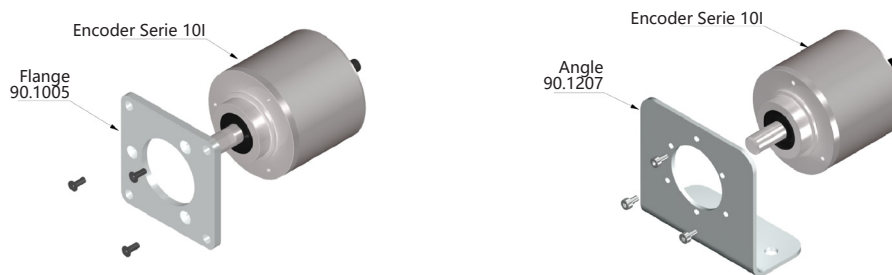

All the accessories available in the section "MOUNTING ACCESSORIES".