



SERIE 11

INCREMENTAL SOLID SHAFT ENCODER COST OPTIMIZED FOR INDUSTRIAL APPLICATIONS

- Resolution up to 5000 pulses per turn
- External diameter 58 mm
- Shaft Ø 10 mm
- Protection class IP65 according to DIN EN 60529
- Connection by cable (other cable length available)



Optical Encoder	Incremental Encoder	High shaft load capacity	Vibration and shock resistant	IP65	Temperature range	Express Delivery

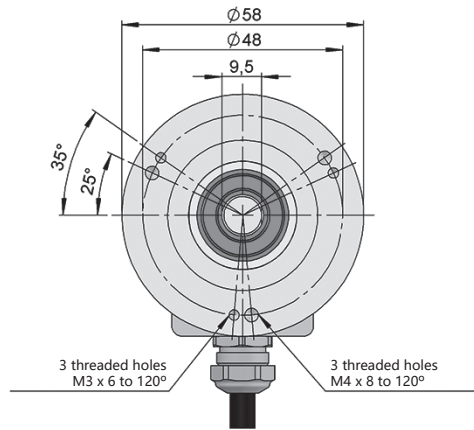
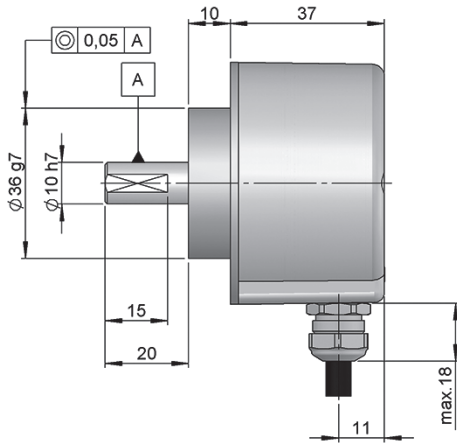

Drawing shaft type 1, connection type 3, without flange

REFERENCE

Reference example: 11-11639-1024

Serie	Solid shaft	Flange	Output signals	Connection	Power Supply / Electronic output	Pulses number	Special customer
11 -	<input type="checkbox"/>	<input type="checkbox"/>	<input type="checkbox"/>	<input type="checkbox"/>	<input type="checkbox"/> -	<input type="checkbox"/> <input type="checkbox"/> <input type="checkbox"/> <input type="checkbox"/>	<input type="checkbox"/> <input type="checkbox"/> <input type="checkbox"/> <input type="checkbox"/>
	1. Ø 10x20 mm	1. None (*)	1. A 2. AB 3. AB, \bar{Z} 5. AB, \overline{AB} 6. ABZ, \overline{ABZ} 9. ABZ	3. Radial cable	0. 11...30 VDC / NPN Open collector 11...30 VDC 6. 11...30 VDC / RS422 5 VDC (compatible TTL) 7. 5 VDC / RS422 5 VDC (compatible TTL) 9. 11...30 VDC / Line driver differential Push-Pull 11...30 VDC		ST00. -40°C

Order your reference Step file 3D

info@encoderhohner.com
service available in 24 h

(*) Flange mounting available, upon request (90.1002 and 90.1005).



SERIE 11

INCREMENTAL SOLID SHAFT ENCODER COST OPTIMIZED FOR INDUSTRIAL APPLICATIONS

MECHANICAL SPECIFICATIONS

Materials	Cover: Aluminium Housing: Aluminium Shaft: Stainless Steel
Bearings	Ballraces
Bearings lifetime	1x10 ¹⁰ rev.
Maximum number of revolutions permitted mechanically	6000 rpm
Protection against dust and splashes according to DIN EN 60529	IP65
Rotor inertia moment	30 gcm ²
Starting torque at 20°C (68°F)	≤ 0.02 Nm
Maximum load permitted on axial shaft	40 N
Maximum load permitted on radial shaft	80 N
Weight aprox.	0.5 Kg
Operating temperature range	-20°C to +80°C - Standard -40°C to +80°C - Special Customer ST00
Vibration according to DIN EN 60068-2-6	100 m/s ² (10Hz...2000Hz)
Shock according to DIN EN 60068-2-27	1000 m/s ² (6ms)
Maximum pulses per turn	5000
Radial connection	2 meters cable (other cable lengths available or connector mounted at the end of the cable, upon request)

OUTPUT SIGNALS

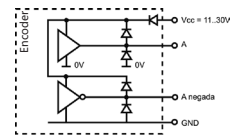
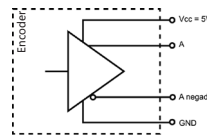
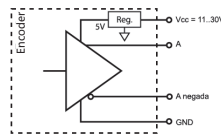
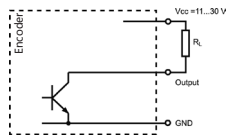

OUTPUT CIRCUIT	NPN Open Collector	RS422 (TTL compatible)	RS422 (TTL compatible)	Push-Pull Differential
Reference code	0	6	7	9
Power supply	11...30 VDC	11...30 VDC	5 VDC ±5%	11...30 VDC
Output voltage	11...30 VDC	5 VDC	5 VDC	11...30 VDC
Consumption	40 mA	Typical: 80 mA Max: 160 mA	Typical: 70 mA Max: 150 mA	Typical: 45 mA Max: 150 mA
Max. load capability / channel	40 mA	±20 mA	±20 mA	±30 mA
Length of cable allowed	50 m (24 VDC)	1200 m	1200 m	100 m
“Low” signal level	VOL < 0.4 VDC (24 VDC)	VOL < 0.5 VDC	VOL < 0.5 VDC	VOL < 2.5 VDC
“High” signal level	VOH > 22 VDC (24 VDC)	VOH > 2.5 VDC	VOH > 2.5 VDC	VOH > VCC – 3 VDC
Frequency	100 kHz	300 kHz	300 kHz	200 kHz
Short circuit protection	Not permanent	Yes	Yes	Yes
Protection polarity inversion	Yes	Yes	No	Yes

Channel B leads (90° electric) channel A, view from the shaft, shaft rotating clockwise

SERIE 11

INCREMENTAL SOLID SHAFT ENCODER COST OPTIMIZED FOR INDUSTRIAL APPLICATIONS

CONNECTION



	Cable 2x2x0.14+1x0.14 95.0008002	Cable 3x2x0.14+2x0.34 95.0008003 (*)
GND	Yellow (YE)	Black (BK)
+UB	White (WH)	Red (RD)
A	Brown (BN)	Yellow (YE)
B	Green (GN)	Green (GN)
\bar{A}	-	Brown (BN)
\bar{B}	-	Blue (BU)
Z	Grey (GY)	Grey (GY)
\bar{Z}	Grey (GY)	Orange (OG)
Case	Shield	Shield

(*) Cable 3x2x0.14+2x0.34 only for encoders with inverted signals.

ACCESSORIES EXAMPLES

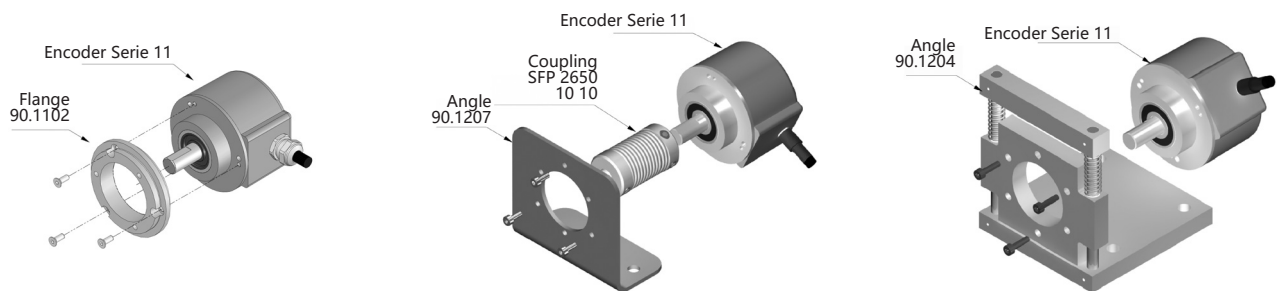

All the accessories available in the section "MOUNTING ACCESSORIES".