



# SERIE 19

## HIGH RESOLUTION BLIND HOLLOW SHAFT INCREMENTAL ENCODER FOR INDUSTRIAL APPLICATIONS

- Resolution up to 50000 pulses per turn
- External diameter 58 mm
- Blind hollow shaft  $\varnothing$  6, 8, 10, 12, 14 or 15 mm
- Protection class IP67 according to DIN EN 60529
- Shaft fixing through clamp
- Anti-rotation system through flexible flange or pin torque support
- Connection by cable (other cable length available) or industrial connector M12, M23



### Clamp

HOLLOW SHAFT	$\varnothing$ A
1	6 mm
3	8 mm
4	10 mm
5	12 mm
7	14 mm
8	15 mm

SERIE	C	D
19	42 mm	0,5 mm
19A	51,8 mm	1 mm

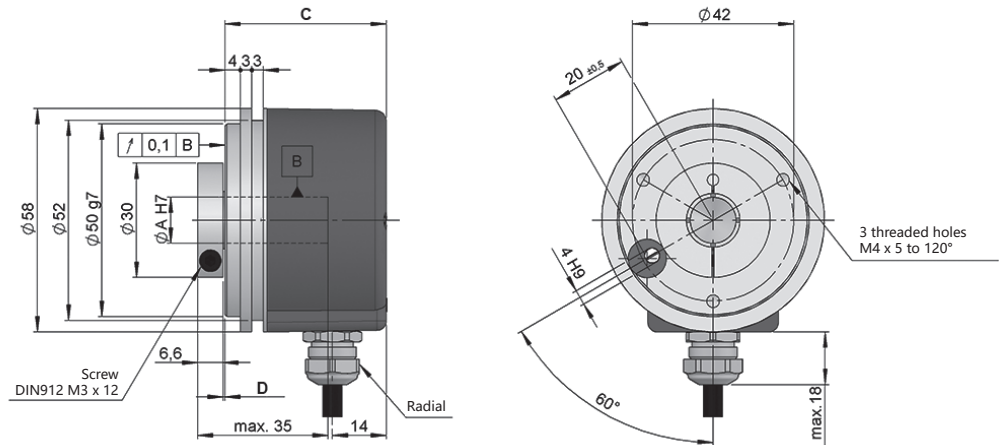

Drawing S19 blind hollow shaft type 5, connection type 3

### REFERENCE

Reference example: 19-15639-1024

Serie	Mechanical option	Blind-Hollow shaft	Output signals	Connection	Power Supply / Electronic output	Pulses number	Special customer
19/19A -	<input type="checkbox"/>	<input type="checkbox"/>	<input type="checkbox"/>	<input type="checkbox"/>	<input type="checkbox"/> -	<input type="checkbox"/> <input type="checkbox"/> <input type="checkbox"/> <input type="checkbox"/> <input type="checkbox"/> <input type="checkbox"/>	<input type="checkbox"/> <input type="checkbox"/> <input type="checkbox"/> <input type="checkbox"/>
19. IP65 19A. IP67	1. Clamp	1. $\varnothing$ 6x26 mm 3. $\varnothing$ 8x26 mm 4. $\varnothing$ 10x26 mm 5. $\varnothing$ 12x26 mm 7. $\varnothing$ 14x26 mm 8. $\varnothing$ 15x26 mm	1. A 2. AB 3. AB, $\bar{Z}$ 5. AB, $\overline{AB}$ 6. ABZ, $\overline{ABZ}$ 9. ABZ	3. Radial cable 5. Radial M23 12p CW L. Radial M12 8p CCW (**)	0. 11...30 VDC / NPN Open collector 11..30 VDC 6. 11...30 VDC / RS422 5 VDC (compatible TTL) 7. 5 VDC / RS422 5 VDC (compatible TTL) 9. 11..30 VDC / Line driver differential Push-Pull 11..30 VDC	(*)	HT00. -40°C

Order your reference  
Step file 3D

info@encoderhohner.com  
service available in 24 h

(\*) 10000 to 50000 pulses with interpolation. Available 10000 direct optical pulses without interpolating upon request.

(\*\*) Special customer for connection options with axial outputs, upon request.

The required anti-rotation system is not included in the reference (order separately). Anti-rotation system is supplied disassembled and includes the screws required for assembly to the encoder. All systems available in the sections "MOUNTING ACCESSORIES".



# SERIE 19

## HIGH RESOLUTION BLIND HOLLOW SHAFT INCREMENTAL ENCODER FOR INDUSTRIAL APPLICATIONS

### MECHANICAL SPECIFICATIONS

Materials	Cover: Aluminium Housing: Aluminium Shaft: Stainless Steel
Bearings	Ballraces
Bearings lifetime	1x10 <sup>10</sup> rev.
Housing fixing	Anti-rotation pin or flexible flange
Permitted misalignment	±0.5 mm axial, ±0.3 mm radial (90.1014, 90.1024)
Shaft fixing	Clamp
Blind hollow shaft diameter	6, 8, 10, 12, 14 or 15 mm
Maximum number of revolutions permitted mechanically	6000 rpm
Protection against dust and splashes according to DIN EN 60529	IP65 - Standard IP67 - Option 19A
Rotor inertia moment	30 gcm <sup>2</sup> (19) 50 gcm <sup>2</sup> (19A)
Starting torque at 20°C (68°F)	≤ 0.02 Nm (19) ≤ 0.04 Nm (19A)
Maximum load permitted on axial shaft	40 N
Maximum load permitted on radial shaft	80 N
Weight aprox.	0.5 Kg
Operating temperature range	-20°C to +80°C - Standard -40°C to +80°C - Special Customer HT00
Vibration according to DIN EN 60068-2-6	100 m/s <sup>2</sup> (10Hz...2000Hz)
Shock according to DIN EN 60068-2-27	1000 m/s <sup>2</sup> (6ms)
Maximum pulses per turn	50000
Radial connection	2 meters cable or industrial connector M12, M23 (other cable lengths available on order) Female connector not included

# SERIE 19

## HIGH RESOLUTION BLIND HOLLOW SHAFT INCREMENTAL ENCODER FOR INDUSTRIAL APPLICATIONS

### OUTPUT SIGNALS

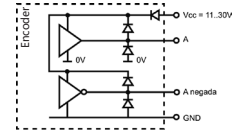
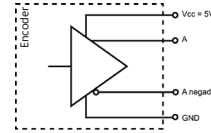
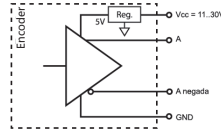
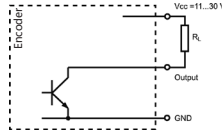

OUTPUT CIRCUIT	NPN Open Collector	RS422 (TTL compatible)	RS422 (TTL compatible)	Push-Pull Differential
Reference code	0	6	7	9
Power supply	11...30 VDC	11...30 VDC	5 VDC ±5%	11...30 VDC
Output voltage	11...30 VDC	5 VDC	5 VDC	11...30 VDC
Consumption	40 mA	Typical: 80 mA Max: 160 mA	Typical: 70 mA Max: 150 mA	Typical: 45 mA Max: 150 mA
Max. load capability / channel	40 mA	±20 mA	±20 mA	±30 mA
Length of cable allowed	50 m (24 VDC)	1200 m	1200 m	100 m
“Low” signal level	VOL < 0.4 VDC (24 VDC)	VOL < 0.5 VDC	VOL < 0.5 VDC	VOL < 2.5 VDC
“High” signal level	VOH > 22 VDC (24 VDC)	VOH > 2.5 VDC	VOH > 2.5 VDC	VOH > VCC – 3 VDC
Frequency	100 kHz	300 kHz	300 kHz	200 kHz
Short circuit protection	Not permanent	Yes	Yes	Yes
Protection polarity inversion	Yes	Yes	No	Yes

Channel B leads (90° electric) channel A, view from the shaft, shaft rotating clockwise

### CONNECTION



	Cable 2x2x0.14+1x0.14 95.0008002	Cable 3x2x0.14+2x0.34 95.0008003 (*)	Connector M12 8p CCW	Connector M23 12p CW
GND	Yellow (YE)	Black (BK)	1	1
+UB	White (WH)	Red (RD)	2	2
A	Brown (BN)	Yellow (YE)	3	3
B	Green (GN)	Green (GN)	4	4
$\bar{A}$	-	Brown (BN)	5	5
$\bar{B}$	-	Blue (BU)	6	6
Z	Grey (GY)	Grey (GY)	7	7
$\bar{Z}$	Grey (GY)	Orange (OG)	8	8
Case	Shield	Shield	Case	Case

(\*) Cable 3x2x0.14+2x0.34 only for encoders with inverted signals.

# SERIE 19

HIGH RESOLUTION BLIND HOLLOW SHAFT INCREMENTAL ENCODER FOR INDUSTRIAL APPLICATIONS

## ACCESSORIES EXAMPLES

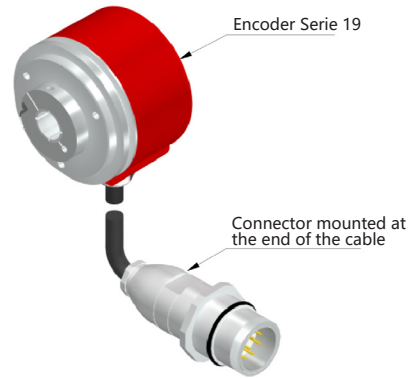
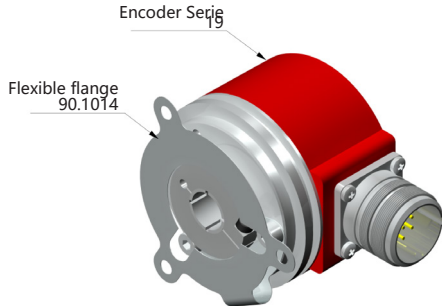

All the accessories available in the section "MOUNTING ACCESSORIES".

## CONNECTION DIMENSIONS

Female connector not included

### Connection 5

Radial  
M23 12p  
male panel  
<< clockwise >>

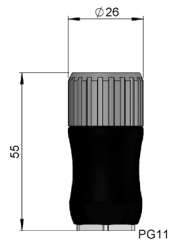
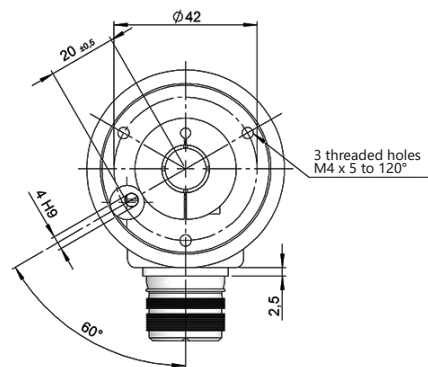
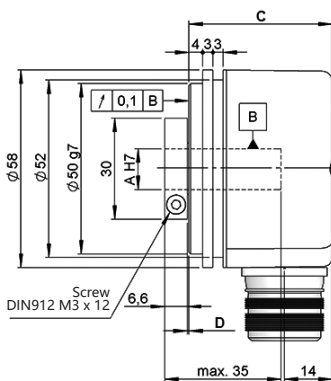

Female connector  
95.0007131



Pre-assembled cable

Without inverted signals: 89.005.01.019.XX  
With inverted signals: 89.005.02.000.XX  
Length in meters

### Connection L

Radial  
M12 8p  
male panel  
counter clockwise

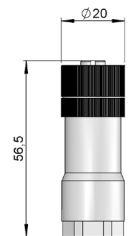
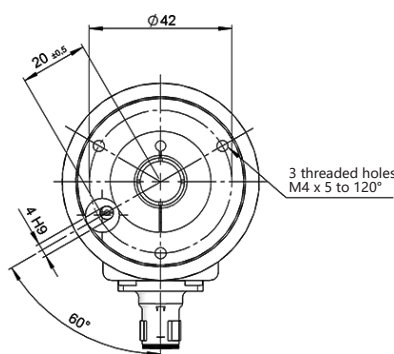
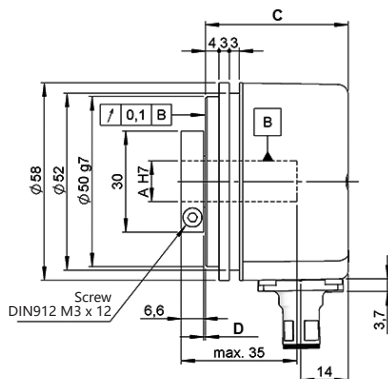

Female connector  
95.0007152



Pre-assembled cable

Without inverted signals: 89.003.01.000.XX  
With inverted signals: 89.003.02.000.XX  
Length in meters

# SERIE 19

HIGH RESOLUTION BLIND HOLLOW SHAFT INCREMENTAL ENCODER FOR INDUSTRIAL APPLICATIONS

## ANTI-ROTATION SYSTEMS DIMENSIONS

**Anti-rotation pin**  
90.1040

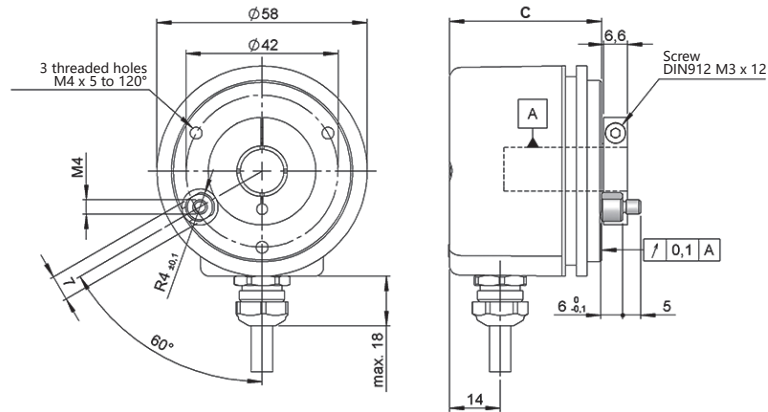

90.1040



**Flexible flange**  
90.1014

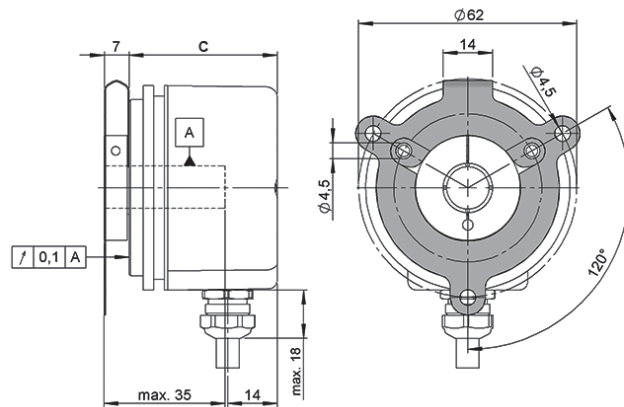

90.1014



**Flexible flange**  
90.1018

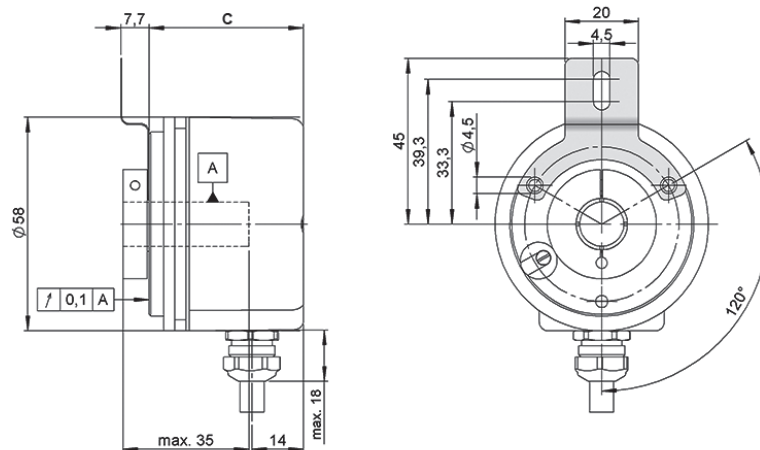

90.1018



# SERIE 19

HIGH RESOLUTION BLIND HOLLOW SHAFT INCREMENTAL ENCODER FOR INDUSTRIAL APPLICATIONS

**Flexible flange**  
90.1020

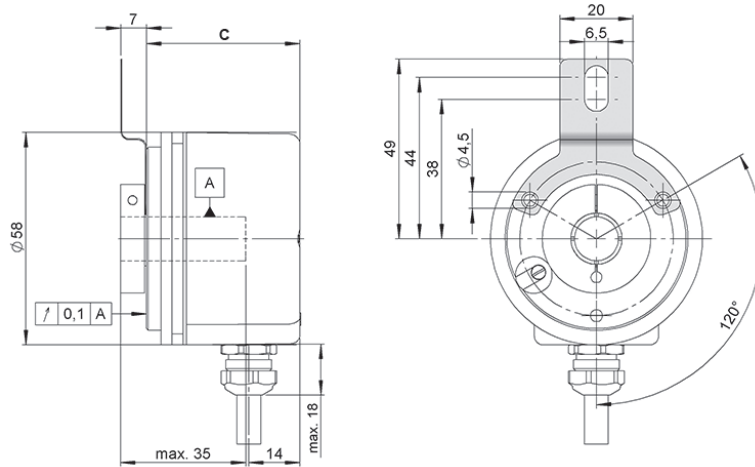

90.1020



**Flexible flange**  
90.1024

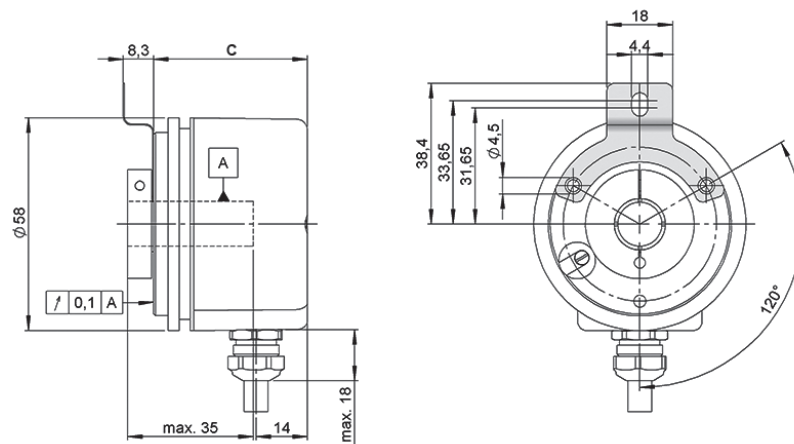

90.1024



**Flexible flange**  
90.1027

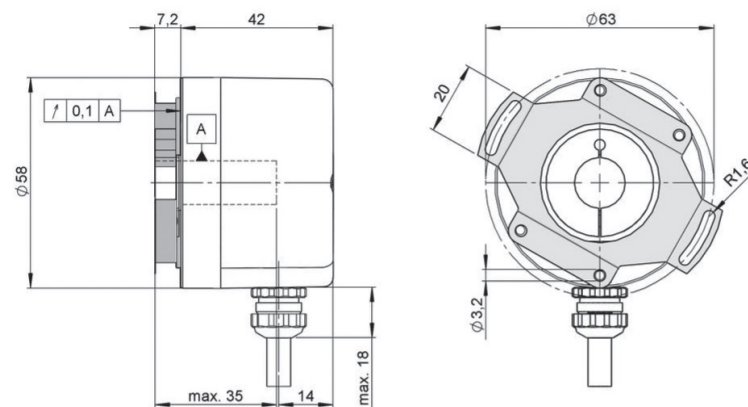

90.1027

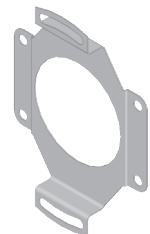

This flexible flange requires a special customer code in the reference:  
19-XXXXX-XXXXX.HG01

# SERIE 19

HIGH RESOLUTION BLIND HOLLOW SHAFT INCREMENTAL ENCODER FOR INDUSTRIAL APPLICATIONS

## Flexible flange 90.1045

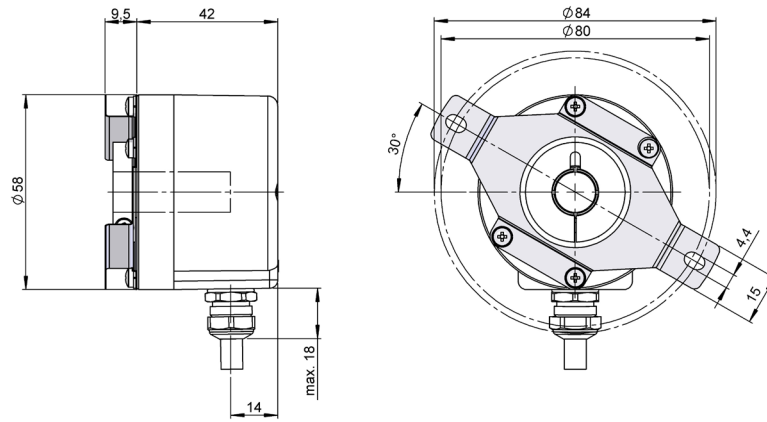

90.1045

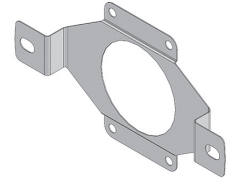

This flexible flange requires a special customer code in the reference:  
19-XXXXX-XXXXX.HG01

## Flexible flange 90.1075

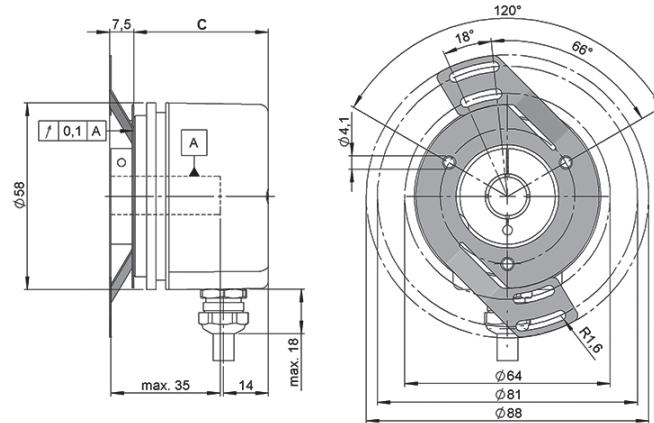

90.1075



## Flexible flange 90.1076

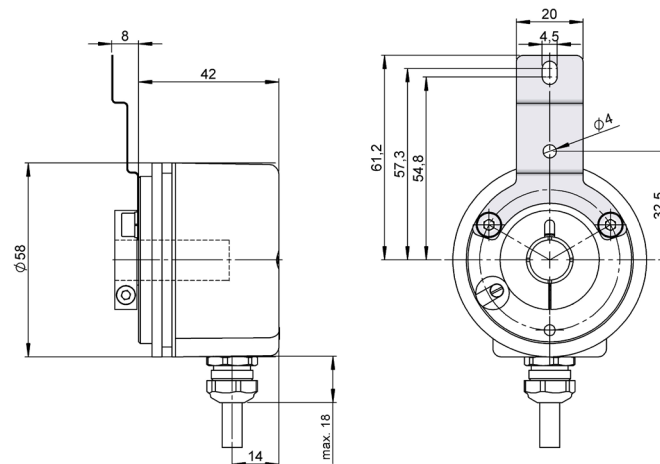

90.1076

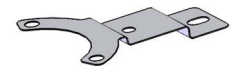

# SERIE 19

## HIGH RESOLUTION BLIND HOLLOW SHAFT INCREMENTAL ENCODER FOR INDUSTRIAL APPLICATIONS

**Flexible flange**  
90.1095

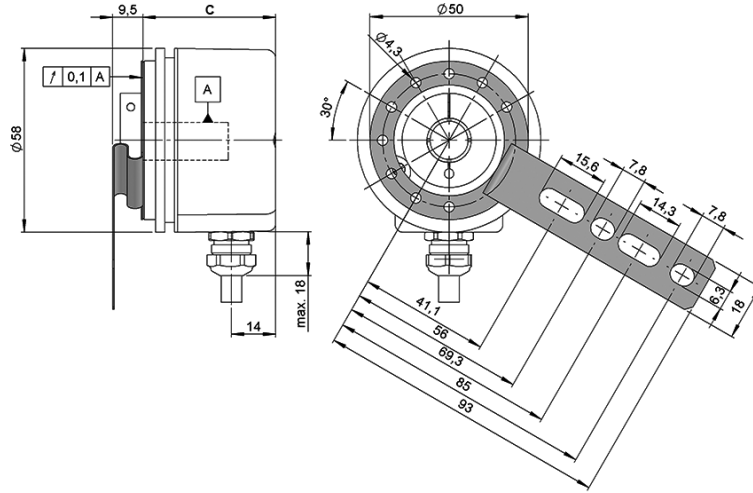

90.1095



**Flexible flange**  
93.0102090

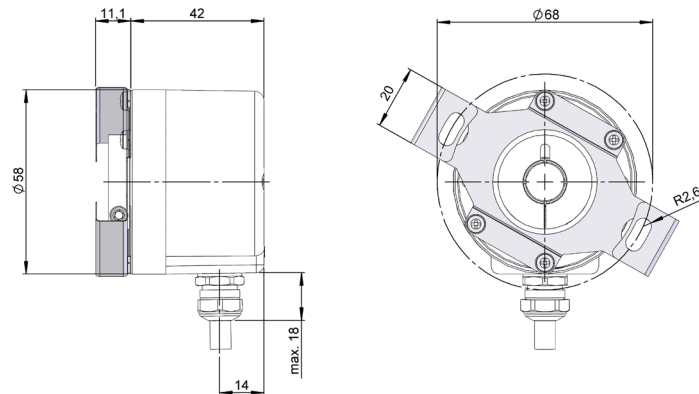

93.0102090

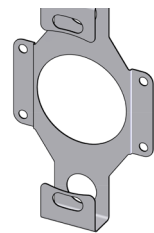

This flexible flange requires a special customer code in the reference:  
19-XXXX-XXXX.HG01