



SERIE 59S

INCREMENTAL HOLLOW SHAFT ENCODER FOR INDUSTRIAL APPLICATIONS

SIN/COS

- Resolution 2048 pulses per turn
- Shaft fixing through front or rear clamp
- External diameter 58 mm
- Hollow shaft \varnothing 10, 12 or 14 mm
- Protection class IP65 according to DIN EN 60529
- Anti-rotation system through flexible flange or anti-turn stick
- Connection by cable (other cable length available) or industrial connector M12 or M23



Rear clamp

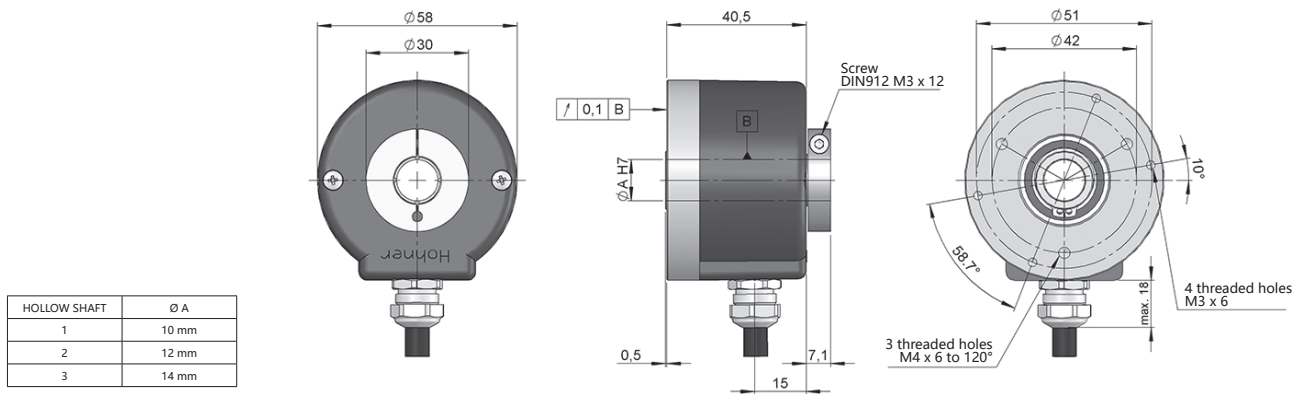

Drawing mechanical option type 1, hollow shaft type 2, connection type 1

Frontal clamp

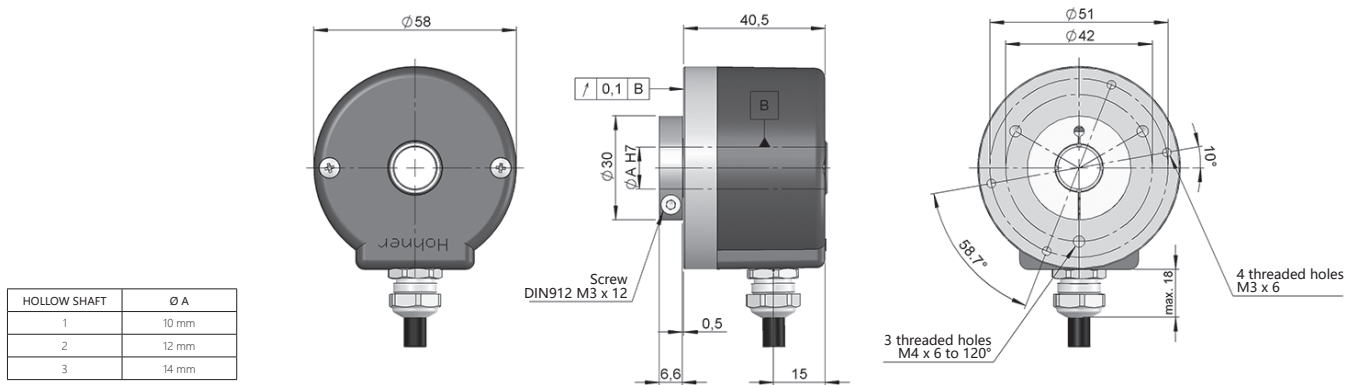

Drawing mechanical option type 2, hollow shaft type 2, connection type 1



SERIE 59S

INCREMENTAL HOLLOW SHAFT ENCODER FOR INDUSTRIAL APPLICATIONS

SIN/COS

REFERENCE								Reference example: 59S-21117-2048
Serie	Mechanical option	Hollow shaft	Output signals	Connection	Power Supply / Electronic output	Pulses number	Special customer	
59S -	<input type="checkbox"/>	<input type="checkbox"/>	<input type="checkbox"/>	<input type="checkbox"/>	<input type="checkbox"/> -	2 0 4 8	<input type="checkbox"/> <input type="checkbox"/> <input type="checkbox"/> <input type="checkbox"/>	
	1. Rear clamp 2. Frontal clamp	1. Ø 10 mm 2. Ø 12 mm 3. Ø 14 mm	1. ABZ, \overline{ABZ} 2. AB, \overline{AB}	1. Radial cable 2. Radial M23 12p CW 3. Radial M12 8p CCW	7. 5 VDC / SIN-COS 1Vpp 5 VDC			

Order your reference Step
file 3D

info@encoderhohner.com

service available in 24 h

The required anti-rotation system is not included in the reference (order separately). Anti-rotation system is supplied disassembled and includes the screws required for assembly to the encoder. All systems available in the sections "MOUNTING ACCESSORIES".

MECHANICAL SPECIFICATIONS

Materials	Cover: Aluminium Housing: Aluminium Shaft: Treated aluminium / Stainless Steel
Bearings	Ballraces
Bearings lifetime	1x10 ¹⁰ rev.
Housing fixing	Flexible flange or Anti-turn stick (not included)
Permitted misalignment	±0.5 mm axial, ±0.3 mm radial (90.1014, 90.1024)
Shaft fixing	Front or Rear clamp
Hollow shaft diameter	10, 12 or 14 mm
Maximum number of revolutions permitted mechanically	6000 rpm
Protection against dust and splashes according to DIN EN 60529	IP65
Rotor inertia moment	30 gcm ²
Starting torque at 20°C (68°F)	≤ 0.02 Nm
Maximum load permitted on axial shaft	40 N
Maximum load permitted on radial shaft	80 N
Weight aprox.	0.5 Kg
Operating temperature range	-20°C to +80°C
Vibration according to DIN EN 60068-2-6	100 m/s ² (10Hz...2000Hz)
Shock according to DIN EN 60068-2-27	1000 m/s ² (6ms)
Number of pulses per turn	2048
Axial or radial connection	2 meters cable or industrial connector M12 or M23 (other cable lengths available on order) Female connector not included

SERIE 59S

INCREMENTAL HOLLOW SHAFT ENCODER FOR INDUSTRIAL APPLICATIONS

SIN/COS

OUTPUT SIGNALS

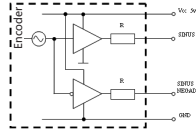

OUTPUT CIRCUIT	Sine-wave
Reference code	7
Power supply	5 VDC ±10%
Output voltage	5 VDC
Consumption	Typical: 40 mA Max: 90 mA
Length of cable allowed	50 m
Signal type	SIN/COS, 1Vpp
Output signal level	0.6 to 1.2 Vpp
Signal offset	2.5 VDC
Reference	0.2 to 1 VDC
Frequency	200 kHz
Protection polarity inversion	Not permanent

Cosine leads (90° electric) Sine, view from the shaft, shaft rotating clockwise

CONNECTION



	Cable 3x2x0.14+2x0.34 95.0008003	Connector M12 8p CCW	Connector M23 12p CW
GND	Black (BK)	1	1
+UB	Red (RD)	2	2
A	Yellow (YE)	3	3
B	Green (GN)	4	4
\bar{A}	Brown (BN)	5	5
\bar{B}	Blue (BU)	6	6
Z	Grey (GY)	7	7
\bar{Z}	Orange (OG)	8	8
Case	Shield	Case	Case

A, \bar{A} : Cosine signal
B, \bar{B} : Sine signal

SERIE 59S

INCREMENTAL HOLLOW SHAFT ENCODER FOR INDUSTRIAL APPLICATIONS

SIN/COS

ACCESSORIES EXAMPLES

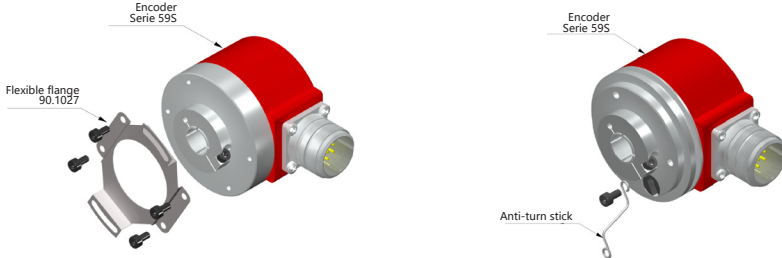

All the accessories available in the section "MOUNTING ACCESSORIES".

CONNECTION DIMENSIONS

Female connector not included

Connection 2
Radial

Fixation 2
Frontal clamp

M23 12p
male panel
clockwise

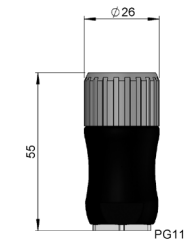
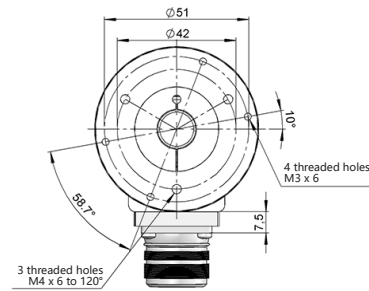
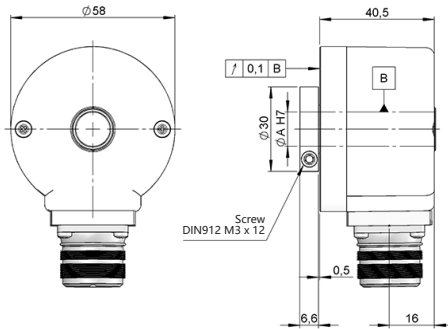

Female connector
95.0007131

Pre-assembled cable
89.005.02.000.XX
Length in meters

Connection 3
Radial

Fixation 2
Frontal clamp

M12 8p
male panel
counter clockwise

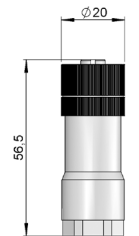
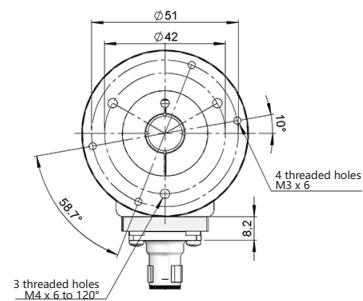
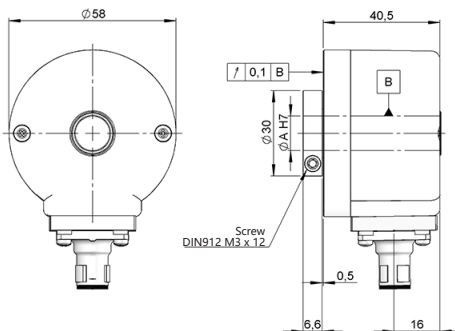

Female connector
95.0007152

Pre-assembled cable
89.003.02.000.XX
Length in meters

SERIE 59S

INCREMENTAL HOLLOW SHAFT ENCODER FOR INDUSTRIAL APPLICATIONS

SIN/COS

ANTI-ROTATION SYSTEMS DIMENSIONS

Flexible flange
90.1014

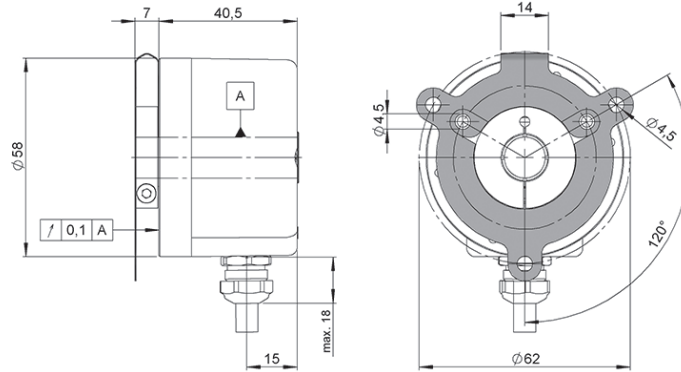

90.1014



Flexible flange
90.1018

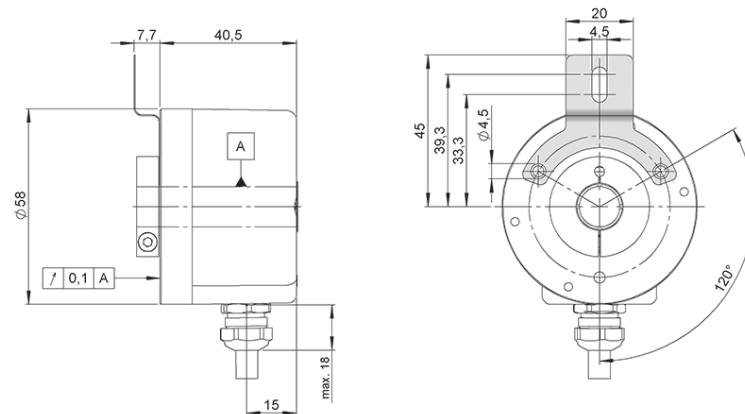

90.1018



Flexible flange
90.1020

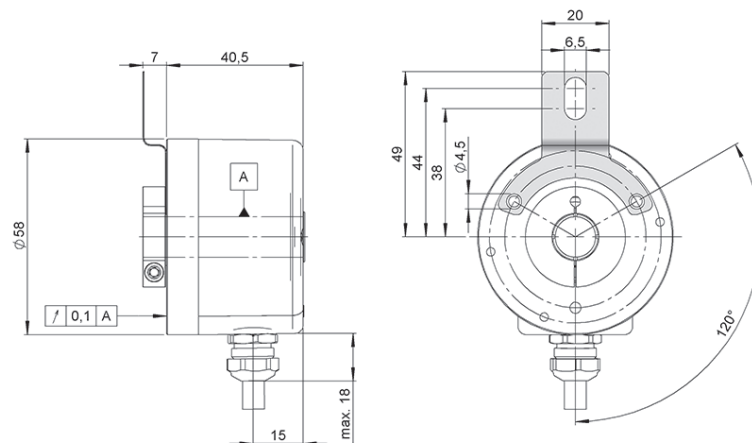

90.1020



SERIE 59S

INCREMENTAL HOLLOW SHAFT ENCODER FOR INDUSTRIAL APPLICATIONS

SIN/COS

Flexible flange
90.1024

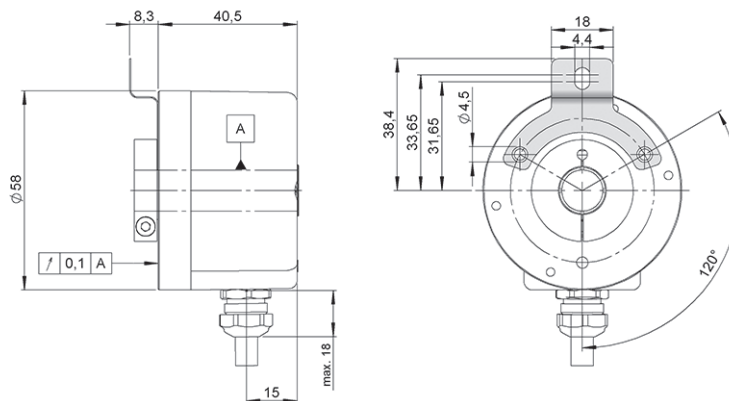

90.1024



Flexible flange
90.1027

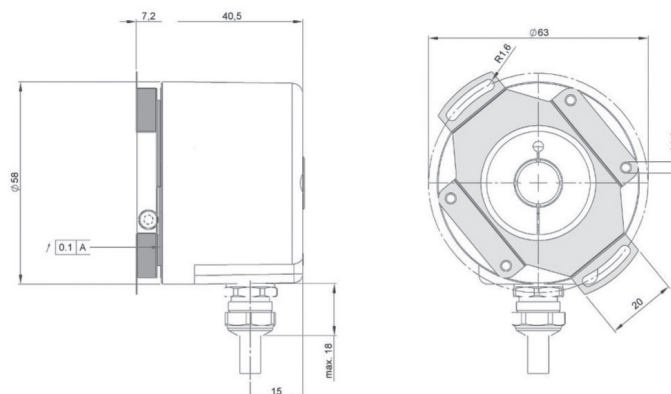

90.1027



Flexible flange
90.1045

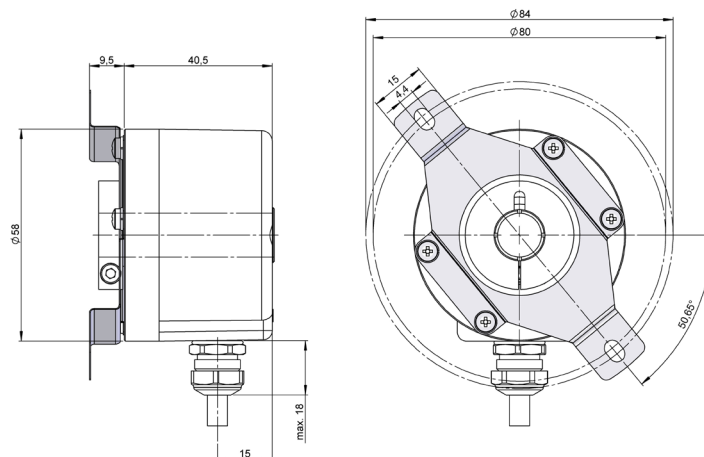

90.1045

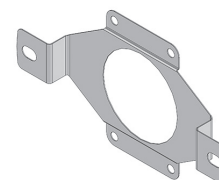

SERIE 59S

INCREMENTAL HOLLOW SHAFT ENCODER FOR INDUSTRIAL APPLICATIONS

SIN/COS

Flexible flange
90.1075

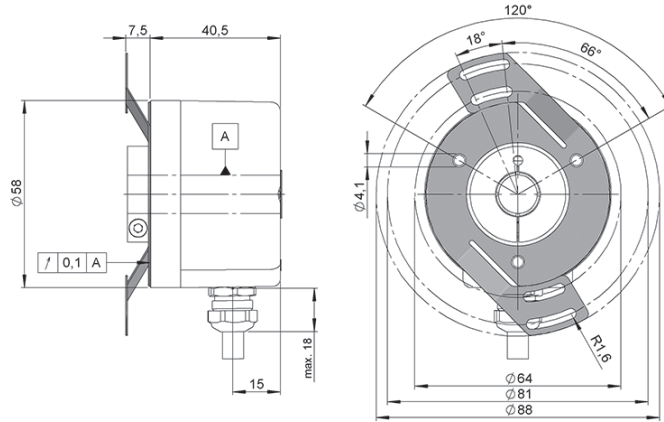

90.1075



Flexible flange
90.1076

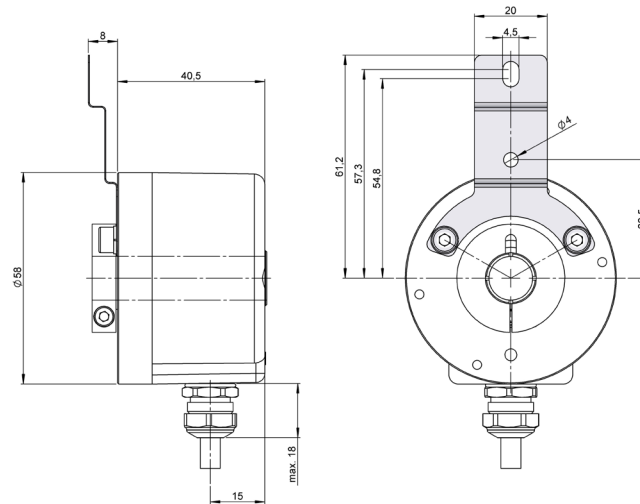

90.1076



Flexible flange
90.1095

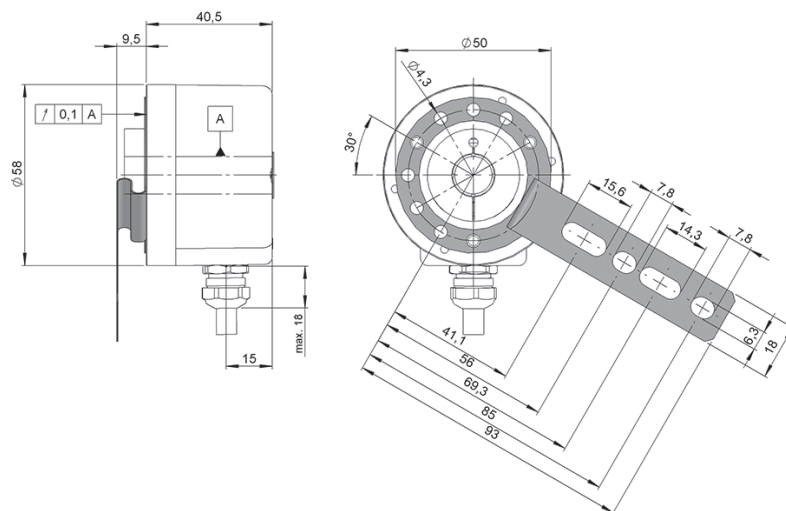

90.1095



SERIE 59S

INCREMENTAL HOLLOW SHAFT ENCODER FOR INDUSTRIAL APPLICATIONS

SIN/COS

Flexible flange
93.0102090

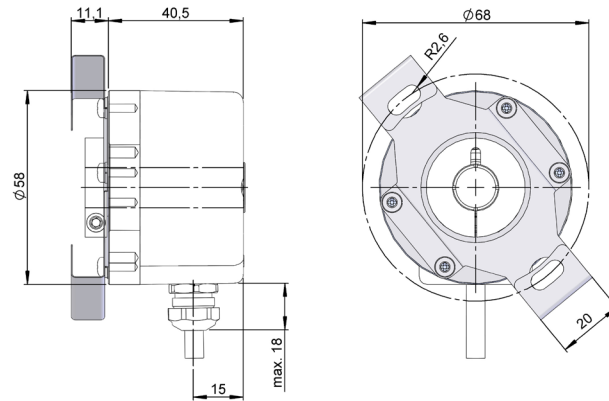

93.0102090

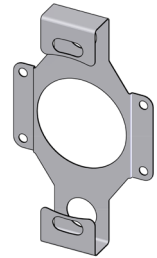

Anti-turn stick

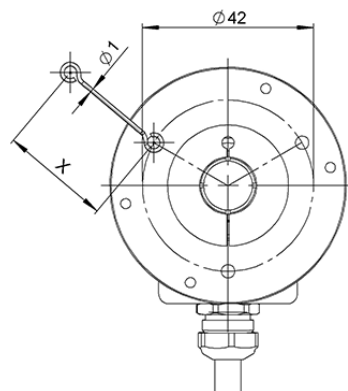

90.1033	X= 33 mm
90.1044	X= 83 mm
90.1043	X= 132 mm

(Other length available on order)