

SERIE 80

INCREMENTAL HOLLOW SHAFT ENCODER FOR INDUSTRIAL APPLICATIONS

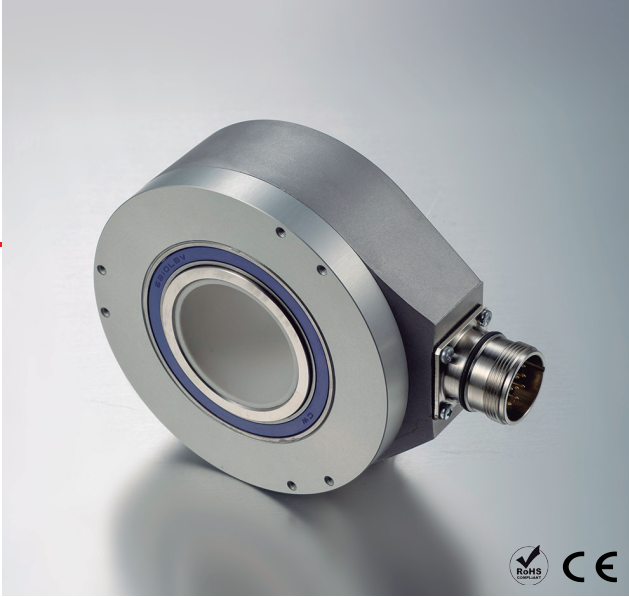

- Resolution up to 5000 pulses per turn
- External diameter 100 mm
- Hollow shaft from Ø 30 to 42 mm
- Protection class IP65 according to DIN EN 60529
- Shaft fixing through front or rear setscrews
- Anti-rotation system through flexible flange
- Connection by cable (other cable length available) or industrial connector M12, M23



Rear setscrews

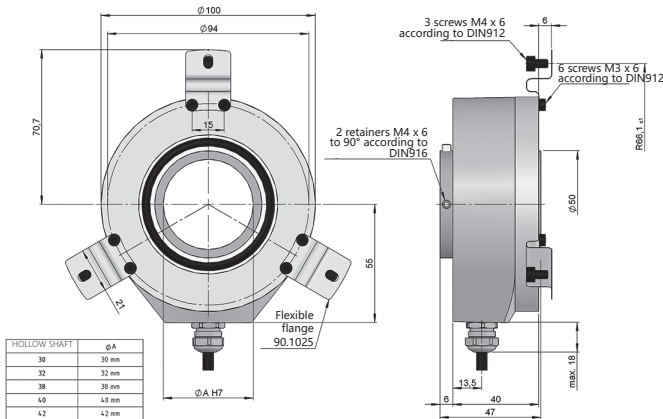

Drawing hollow shaft type 42, mechanical option type 1 with anti-rotation system through flexible flange 90.1025, connection type 1

Frontal setscrews

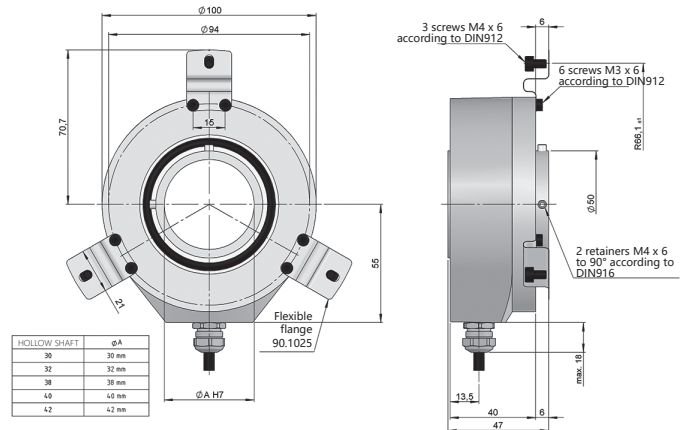

Drawing hollow shaft type 42, mechanical option type 2 with anti-rotation system through flexible flange 90.1025, connection type 1

REFERENCE

Reference example: 80-130111-3600

Serie	Mechanical option	Hollow shaft	Output signals	Connection	Power Supply / Electronic output	Pulses number	Special customer
80 -	<input type="checkbox"/>	<input type="checkbox"/>	<input type="checkbox"/>	<input type="checkbox"/>	<input type="checkbox"/>	<input type="checkbox"/>	<input type="checkbox"/>
	1. Rear setscrews 2. Frontal setscrews	30. Ø 30 mm 32. Ø 32 mm 38. Ø 38 mm 40. Ø 40 mm 42. Ø 42 mm	1. ABZ, \overline{ABZ} 2. AB, \overline{AB}	1. Radial cable 2. Radial M23 12p CW 3. Radial M12 8p CCW	0. 11...30 VDC / NPN Open collector 11...30 VDC 1. 11...30 VDC / Line driver differential Push-Pull 11...30 VDC 2. 5 VDC / RS422 5 VDC (compatible TTL) 6. 11...30 VDC / RS422 5 VDC (compatible TTL)		MT00. -40°C

Order your reference Step file 3D

info@encoderhohner.com
service available in 24 h

The required anti-rotation system is not included in the reference (order separately). Anti-rotation system is supplied disassembled and includes the screws required for assembly to the encoder. All systems available in the sections "MOUNTING ACCESSORIES".



SERIE 80

INCREMENTAL HOLLOW SHAFT ENCODER FOR INDUSTRIAL APPLICATIONS

MECHANICAL SPECIFICATIONS

Materials	Cover: Aluminium Housing: Aluminium Shaft: Stainless Steel
Bearings	Ballraces
Bearings lifetime	1x10 ¹⁰ rev.
Housing fixing	Flexible flange
Permitted misalignment	±0.5 mm axial, ±0.3 mm radial (90.1025 - one) ±0.4 mm axial, ±0.2 mm radial (90.1025 - three)
Shaft fixing	Front or Rear setscrews
Hollow shaft diameter	30, 32, 38, 40 or 42 mm
Maximum number of revolutions permitted mechanically	3600 rpm
Protection against dust and splashes according to DIN EN 60529	IP65
Rotor inertia moment	≤ 1 - 1.8 Kg cm ²
Starting torque at 20°C (68°F)	≤ 0.04 Nm
Maximum load permitted on axial shaft	≤ 100 N
Maximum load permitted on radial shaft	≤ 200 N
Weight approx.	0.7 Kg
Operating temperature range	-20°C to +80°C - Standard -40°C to +80°C - Special Customer MT00
Vibration according to DIN EN 60068-2-6	100 m/s ² (10Hz...2000Hz)
Shock according to DIN EN 60068-2-27	1000 m/s ² (6ms)
Maximum pulses per turn	5000
Radial connection	2 meters cable or industrial connector M12, M23 (other cable lengths available on order) Female connector not included

OUTPUT SIGNALS

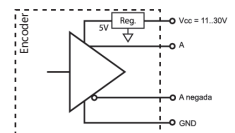
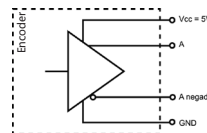
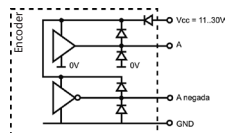
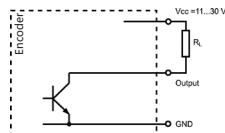

OUTPUT CIRCUIT	NPN Open Collector	Push-Pull Differential	RS422 (TTL compatible)	RS422 (TTL compatible)
Reference code	0	1	2	6
Power supply	11...30 VDC	11...30 VDC	5 VDC ±5%	11...30 VDC
Output voltage	11...30 VDC	11...30 VDC	5 VDC	5 VDC
Consumption	40 mA	Typical: 45 mA Max: 150 mA	Typical: 70 mA Max: 150 mA	Typical: 80 mA Max: 160 mA
Max. load capability / channel	40 mA	±30 mA	±20 mA	±20 mA
Length of cable allowed	50 m (24 VDC)	100 m	1200 m	1200 m
“Low” signal level	VOL < 0.4 VDC (24 VDC)	VOL < 2.5 VDC	VOL < 0.5 VDC	VOL < 0.5 VDC
“High” signal level	VOH > 22 VDC (24 VDC)	VOH > VCC - 3 VDC	VOH > 2.5 VDC	VOH > 2.5 VDC
Frequency	100 kHz	200 kHz	300 kHz	300 kHz
Short circuit protection	Not permanent	Yes	Yes	Yes
Protection polarity inversion	Yes	Yes	No	Yes

Channel B leads (90° electric) channel A, view from the shaft, shaft rotating clockwise

SERIE 80

INCREMENTAL HOLLOW SHAFT ENCODER FOR INDUSTRIAL APPLICATIONS

CONNECTION



	Cable 3x2x0.14+2x0.34 95.0008003	Connector M23 12p CW	Connector M12 8p CCW
GND	Black (BK)	1	1
+UB	Red (RD)	2	2
A	Yellow (YE)	3	3
B	Green (GN)	4	4
\bar{A}	Brown (BN)	5	5
\bar{B}	Blue (BU)	6	6
Z	Grey (GY)	7	7
\bar{Z}	Orange (OG)	8	8
Case	Shield	Case	Case

ACCESSORIES EXAMPLES

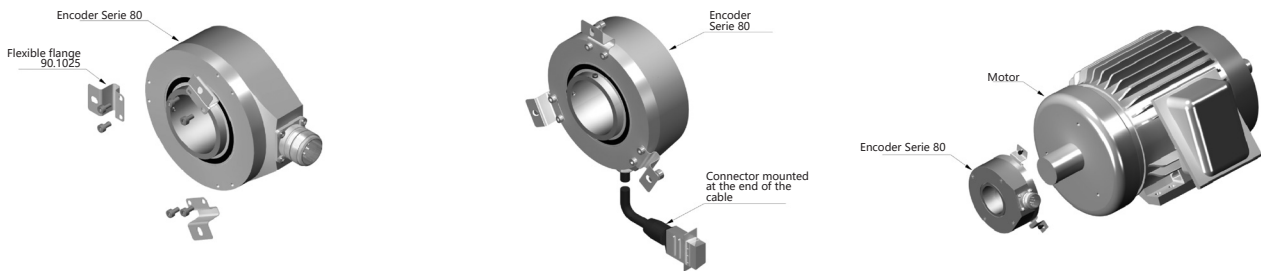

All the accessories available in the section "MOUNTING ACCESSORIES".

CONNECTION DIMENSIONS

Female connector not included

Connection 2
Radial

Fixation 2
Frontal setscrews

M23 12p
male panel
clockwise

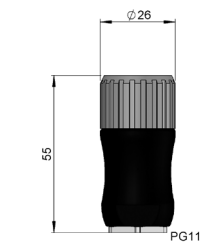
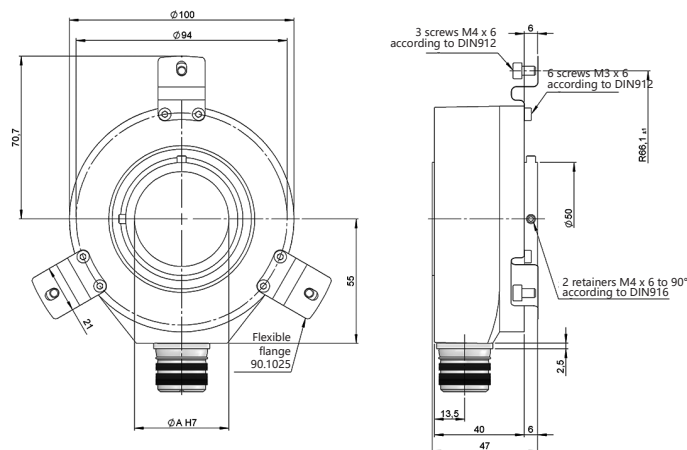

Female connector
95.0007131

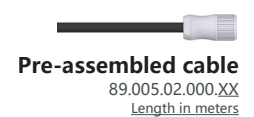

Pre-assembled cable
89.005.02.000.XX
Length in meters

