

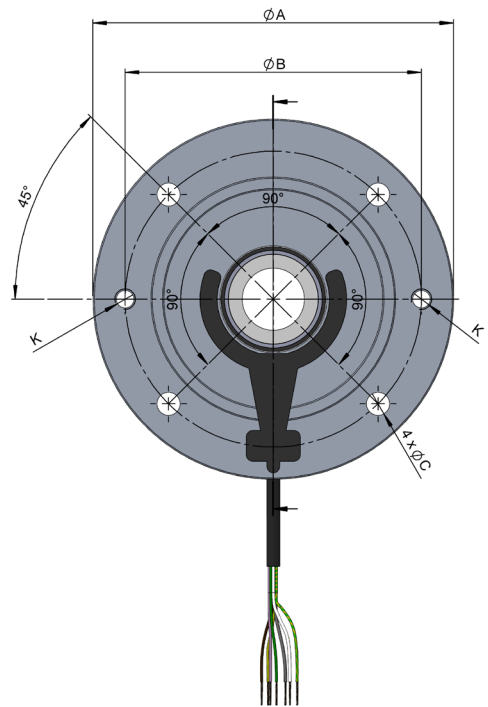

SERIE MRH

MAGNETIC INCREMENTAL ENCODER

- Resolution up to 4096 pulses per turn
- Non-contacting measuring system
- Easy assembly
- High protection class IP67
- Compact dimensions
- For applications under possible adverse ambient conditions (vibrations, humidity, dust, etc.)

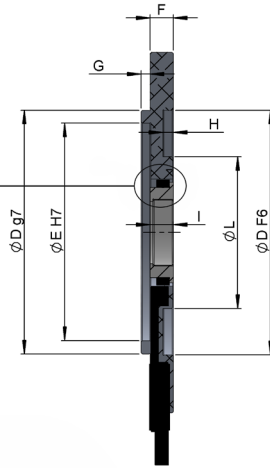
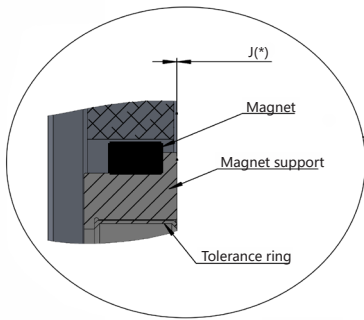
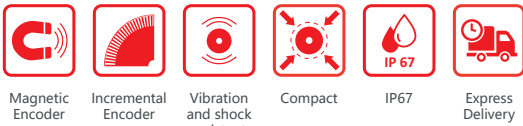

J(*) Mounting distance between support of magnet and surface to fix the sensor.
Mounting tolerance: ± 0.5mm

DIMENSIONS

Ø A	Ø Shaft	Ø B	Ø C	Ø D	Ø E	F	G	H	I	J	K	Ø L
105	9	85	7	70	65	7	2,5	3	7	0	M6	59
	14											
120	9	100	7	80	74	7	3	3,5	7	0	M6	59
	19											
140	11	115	9	95	85	7	3,5	4	7	0	M8	59
	14					9			9			
	24											
160	14	130	9	110	100	7	3,5	4	7	0	M8	59
	19					9			9			
	24											
	28											
200	19	165	11	130	120	9	3,5	4	9	0	M10	59
	24											
250	28	215	13,5	180	170	12	4	5	12	0	M12	59



SERIE MRH

MAGNETIC INCREMENTAL ENCODER

REFERENCE

Reference example: MRH-140-24-01-2048

Serie	External diameter / Shaft diameter	Power Supply / Electronic output	Connection	Resolution	Special Customer
MRH -	□□□ - □□ -	□	□ -	□□□□	□□□□
105-09. Ø 105 mm / Ø 9mm	160-14. Ø 160 mm / Ø 14 mm	0. 5...30 VDC / RS422 5 VDC (compatible TTL)	1. 1m cable	(**)	
105-14. Ø 105 mm / Ø 14 mm	160-19. Ø 160 mm / Ø 19 mm	1. 5...30 VDC / Line driver	2. 30cm cable + connector M12		
120-09. Ø 120 mm / Ø 9 mm	160-24. Ø 160 mm / Ø 24 mm	differential Push-Pull 5...30 VDC	8P CCW		
120-11. Ø 120 mm / Ø 11 mm	160-28. Ø 160 mm / Ø 28 mm				
120-19. Ø 120 mm / Ø 19 mm	200-19. Ø 200 mm / Ø 19 mm				
140-11. Ø 140 mm / Ø 11 mm	200-24. Ø 200 mm / Ø 24 mm				
140-14. Ø 140 mm / Ø 14 mm	200-28. Ø 200 mm / Ø 28 mm				
140-24. Ø 140 mm / Ø 24 mm	250-28. Ø 250 mm / Ø 28 mm				

Order your reference Step
file 3D

info@encoderhohner.com

service available in 24 h

(*) Other options available, upon request.

(**) From 16 ppr to 4096 ppr, in steps of 16 pulses (16, 32, 48, 64...).

MECHANICAL SPECIFICATIONS

Materials	Housing: Aluminium Magnet support: Stainless Steel Magnet: Elastomer
Maximum number of revolutions permitted mechanically	6000 rpm
Shaft diameter	9, 11, 14, 19, 24, 28 mm
Housing fixing	4 holes (see dimensions table Ø B - Ø C)
Motor shaft tolerance	±0.5 mm axial, 0.05 mm radial
Protection against dust and splashes according to DIN EN 60529	IP67
Weight aprox.	Min.. 0.25 Kg Max. 1.4 Kg
Operating temperature range	-20 to +85°C
Vibration according to DIN EN 60068-2-6	100 m/s ² (10Hz...2000Hz)
Shock according to DIN EN 60068-2-27	1000 m/s ² (6ms)
Radial connection	1 meter cable

ELECTRICAL SPECIFICATIONS

Measuring range	0...360°
Resolution	From 16 ppr to 4096 ppr, in steps of 16 pulses (16, 32, 48, 64...)
Power supply	5...30 VDC
Consumption	< 60 mA (without load)
Reverse polarity protection of power supply	Yes
Insulation test	500 V
Insulation resistance	200 MΩ
Impulse sequence	A 90° B Tolerance ± 25° el.
Motor shaft tolerance	According to IEC Dimensions B5 and B14

SERIE MRH

MAGNETIC INCREMENTAL ENCODER

OUTPUT SIGNALS

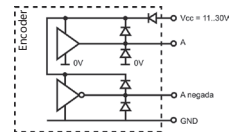
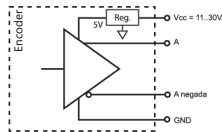

OUTPUT CIRCUIT	RS422 (TTL compatible)	Push-Pull Differential
Reference code	0	1
Electronic Output voltage	5V TTL (RS422 compatible)	5...30 VDC
“High” signal level	> 2.5 V	> VCC - 3 VDC
“Low” signal level	< 0.5 V	< 2.5 VDC
Frequency	≤ 100 kHz	≤ 100 kHz
Duty cycle signal	180° ± 18° el.	180° ± 18° el.
Length of cable allowed	50 m	100 m
Max. load capability / channel	10 mA	40 mA
Output channels	Square wave-Impulse, (4-channel) A+B+ \bar{A} + \bar{B}	Square wave-Impulse, (4-channel) A+B+ \bar{A} + \bar{B}
Short circuit protection	Yes	Yes

CONNECTION

Female connector not included



	Cable 8x0.14 95.0008052	Connector M12 8p CCW
GND	White (WH)	1
+UB	Brown (BN)	2
A	Green (GN)	3
B	Grey (GY)	4
\bar{A}	Yellow (YE)	5
\bar{B}	Pink (PK)	6
Case	Shield	Case

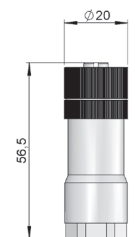

Female connector
95.0007152



Pre-assembled cable
89.003.02.000.XX
Length in meters

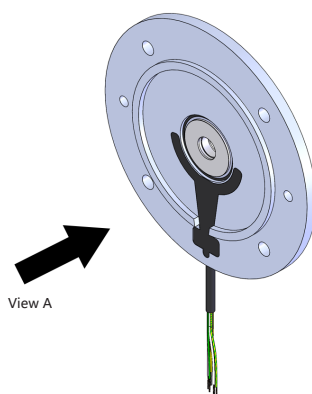

View A

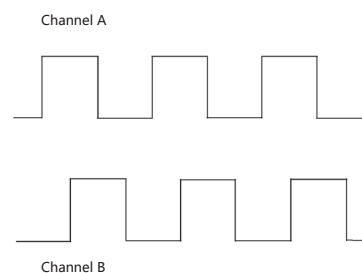

Channel A leads (90° electric) channel B, seen from view A, shaft rotating clockwise.

SERIE MRH

MAGNETIC INCREMENTAL ENCODER

ASSEMBLY INSTRUCTIONS

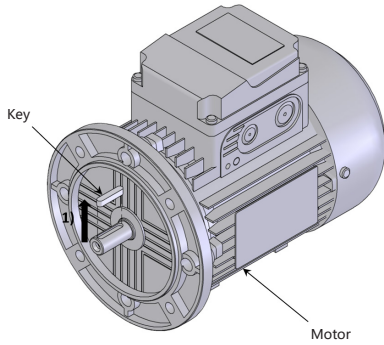

1) Dismount the key.

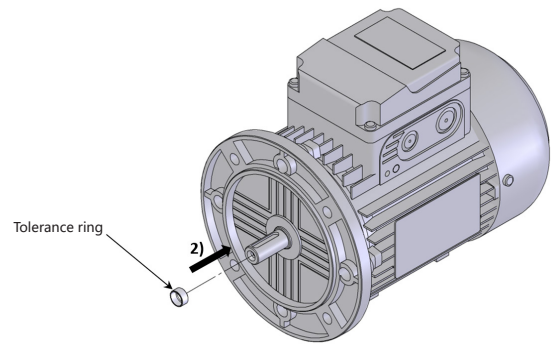

2) Push tolerance ring up to the shoulder of the shaft.

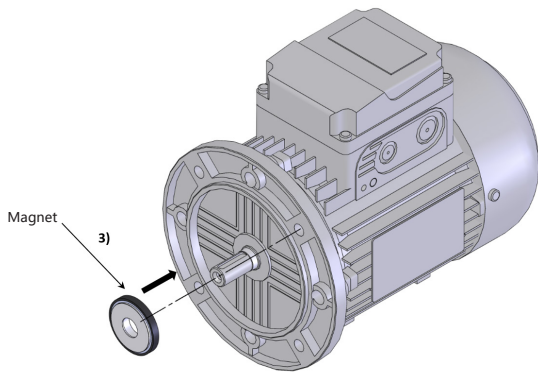

3) Mount magnet embedded with tolerance ring.

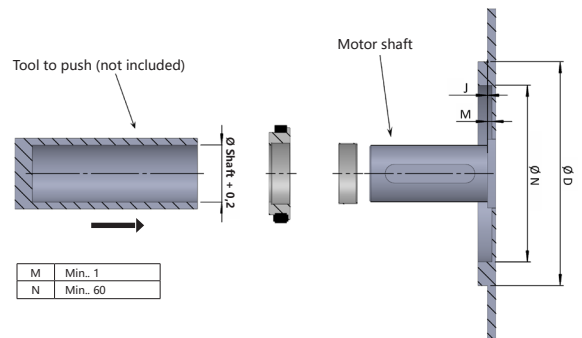

3.1) Recommendation for assembly:

Insert the magnet with the tool by pressing on the magnet support, not on magnet.

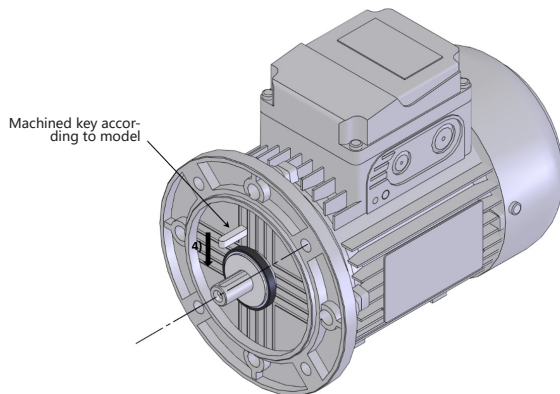

4) Push machined key according to MRH model.

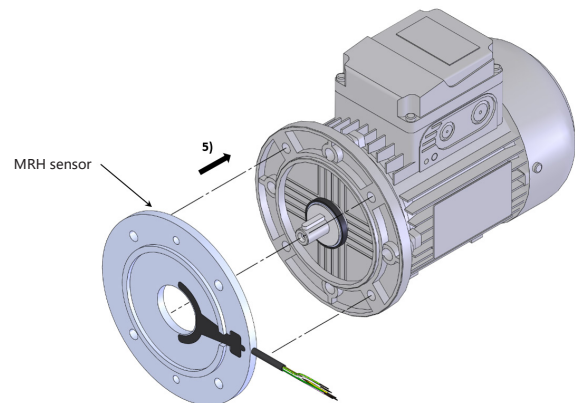

5) Mount MRH sensor.