



# SERIE M100

## BRUSHLESS HOLLOW SHAFT DC MOTOR

- Harmonic Drive gearbox
- Brushless motor
- High accuracy
- High reliability
- Start time 35 Nm
- Excellent regulation at low speeds
- Speed range 0.00125 rpm (0,008°/s) to 6 rpm (40°/s)



Servomotor   EtherCAT   Brushless motor   Harmonic Drive gearbox   Compact

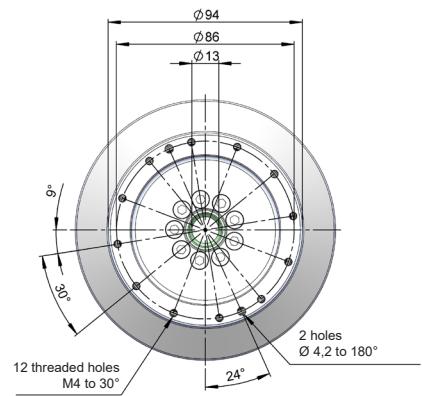
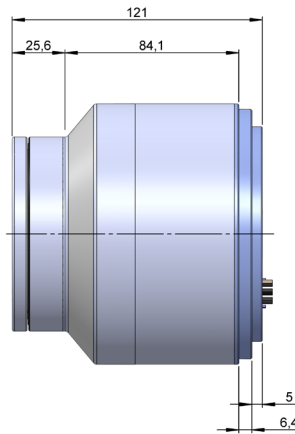
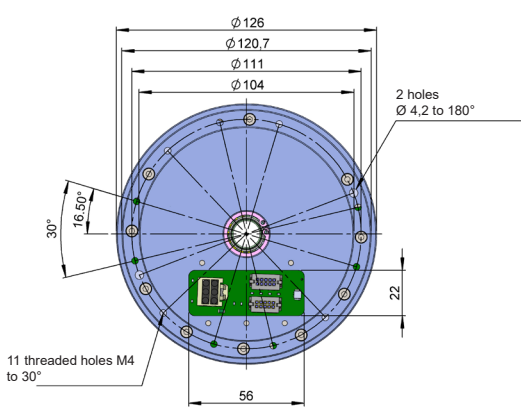

### REFERENCE

Reference example: M100.00.07.A0

Serie	Reference	Version	Review
M100 .	00 .	07 .	A0

### ELECTRICAL SPECIFICATIONS

Interface	EtherCAT
Power supply	24 V
Repeat accuracy	0,05°
Resolution	19 bits
Nominal voltage	24 V
Nominal current	1 A
Motor max current	2 A



# SERIE M100

## BRUSHLESS HOLLOW SHAFT DC MOTOR

### MECHANICAL SPECIFICATIONS

Materials	Housing: Aluminium Shaft: Aluminium
Hollow bore diameter	13 mm
Protection against dust and splashes according to DIN EN 60529	IP40
Nominal / Peak Power	24 / 48 W
Nominal / Peak Torque	35 / 70 Nm
Maximum speed	50° /s <sup>2</sup>
Max. Acceleration	100° /s <sup>2</sup>
Weight aprox.	2 Kg
Operating temperature range	-0°C to +35°C
Gear ratio	897,3:1
Brake	Integrated
Electronics Control	Integrated
Noise level	<= 70 dB

### CONNECTION

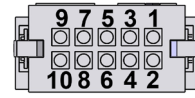
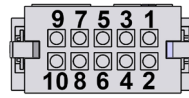
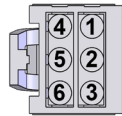

	J1 Power supply connector 6p	J4 EtherCAT Connector 1 10p	J5 EtherCAT Connector 2 10p
ETH1_RX_N		1	1
+LOG_SUP (+24V)		2	2
ETH1_RX_P		3	3
GND	3 - 6	4	4
ETH1_TX_N		5	5
STO2_IN		6	6
ETH1_TX_P		7	7
STO_RET		8	8
PE	2 - 5	9	9
STO1_IN		10	10
+POW_SUP (+24 V)	1 - 4		