



SERIE E58 CS

SOLID SHAFT ABSOLUTE SINGLETURN ENCODER



- Singleturn resolution up to 13 bits
- Magnetic technology
- External diameter 58 mm
- Solid shaft \varnothing 6, 8 and 10 mm
- Protection class IP65 according to DIN EN 60529
- Connection by cable (other cable length available) or industrial connector M23

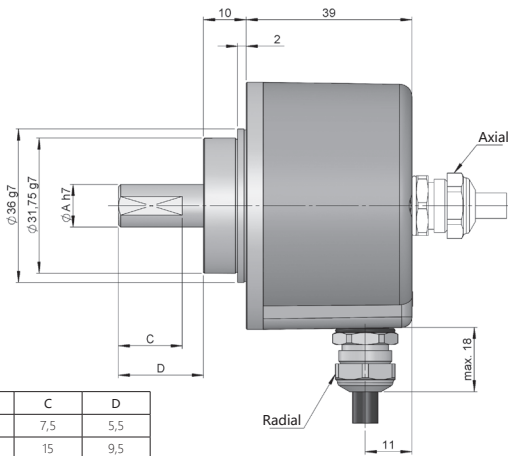

SOLID SHAFT	\varnothing A	B	C	D
1	6	10	7,5	5,5
2	10	20	15	9,5
3	8	20	15	7,5

Drawing connection type 1/2, without flange

REFERENCE

Reference example: E58CS-SSI-12231-12

Serie	Interface	Solid shaft	Flange	Connection	Code	Power Supply / Electronic output	Singleturn resolution	Special customer
E58CS -	SSI -	<input type="checkbox"/>	<input type="checkbox"/>	<input type="checkbox"/>	<input type="checkbox"/>	<input type="checkbox"/> -	<input type="checkbox"/> <input type="checkbox"/>	<input type="checkbox"/> <input type="checkbox"/> <input type="checkbox"/> <input type="checkbox"/>
	SSI, SSI	1. \varnothing 6 mm 2. \varnothing 10 mm 3. \varnothing 8 mm	1. None 2. 90.1002 3. 90.1003 4. 90.1004 5. 90.1005 6. 90.1006	1. Axial cable 2. Radial cable 3. Radial M23 12p 5. Axial M23 12p	1. Binary CW 2. Binary CCW 3. Gray CW 4. Gray CCW	1. 4,75...30 VDC / RS422	09. 9 bits 10. 10 bits 11. 11 bits 12. 12 bits 13. 13 bits	

Order your reference Step file 3D

info@encoderhohner.com

service available in 24 h



SERIE E58 CS

SOLID SHAFT ABSOLUTE SINGLETURN ENCODER



MECHANICAL SPECIFICATIONS

Materials	Cover: Zamac Housing: Aluminium Shaft: Stainless Steel
Bearings	Ballraces
Bearings lifetime	1x10 ¹⁰ rev.
Maximum number of revolutions permitted mechanically	6000 rpm - Standard 10000 rpm - Upon request 12000 rpm (≤ 12 bits) - Upon request
Protection against dust and splashes according to DIN EN 60529	IP65
Rotor inertia moment	40 gcm ²
Starting torque at 20°C (68°F)	≤ 0.02 Nm
Maximum load permitted on axial shaft	20 N
Maximum load permitted on radial shaft	40 N
Weight aprox.	0.5 Kg
Operating temperature range	-40°C to +105°C
Vibration according to DIN EN 60068-2-6	100 m/s ² (10Hz...2000Hz)
Shock according to DIN EN 60068-2-27	1000 m/s ² (6ms)
Axial or radial connection	2 meters cable or industrial connector M23 (other cable lengths available on order) Female connector not included

ELECTRICAL SPECIFICATIONS

Interface	
Electronic output	RS422
Power supply (VDC)	4.75...30 VDC
Consumption	≤ 100 mA
Code	Binary Gray
Protocol	SSI
Singleturn resolution	up to 13 bits
Absolute accuracy	±0.35°
Relative accuracy	±1.5 LSB
Max. load capability / channel	±20 mA
“Low” signal level	< 0,8 VDC
“High” signal level	2 ... 5.5 VDC
Frequency	50 kHz...2 MHz
Short circuit protection	Yes
Protection polarity inversion	Yes

CONNECTION



	Cable 8x0.14 mm ² 95.0008052	Connector M23 12p CW
GND	White (WH)	1
+UB	Brown (BN)	2
DT+	Yellow (YE)	3
DT-	Pink (PK)	4
CK+	Green (GN)	5
CK-	Grey (GY)	6
PRESET (*)	Red (RD)	7
DIR (**)	Blue (BU)	8

(*) Apply a 4.75...30 VDC pulse (more than 1 ms) to set the encoder to Zero and reboot the encoder (turn off and then turn on the power supply).

(**) Connect to 4.75...30 VDC to change direction from default. If this input is not used, it should be connected to GND in order to avoid interferences. The encoder must be always rebooted (turn off and then turn on the power supply) after switching.

SERIE E58 CS

SOLID SHAFT ABSOLUTE SINGLETURN ENCODER



CONNECTION DIMENSIONS

Female connector not included

Connection 3

Radial
M23 12p
male panel
clockwise

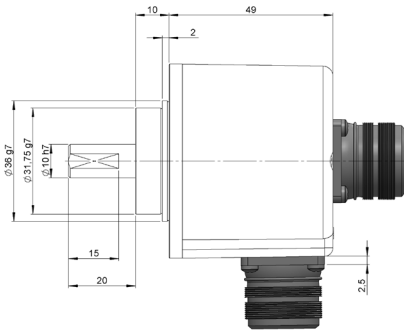

Connection 5

Axial
M23 12p
male panel
clockwise

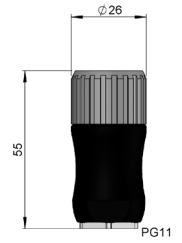
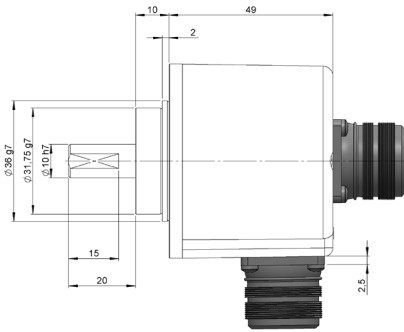

Female connector
95.0007131



Pre-assembled cable
89.005.02.000.XX
Length in meters

FLANGE DIMENSIONS

Flange mounting included

Flange 2 90.1002

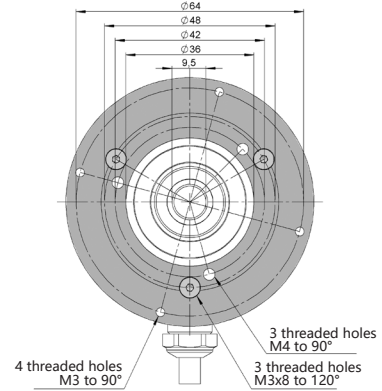
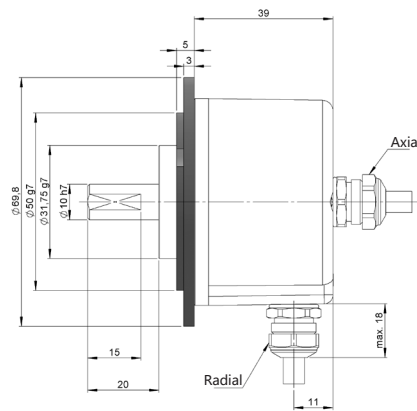

Flange 3 90.1003 Synchro

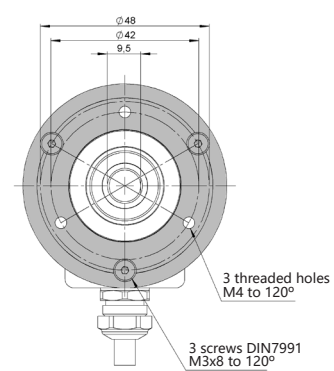
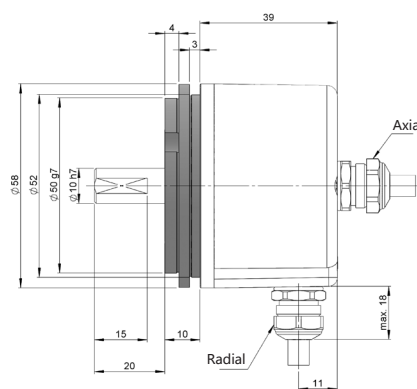

SERIE E58 CS

SOLID SHAFT ABSOLUTE SINGLETURN ENCODER



Flange 4
90.1004

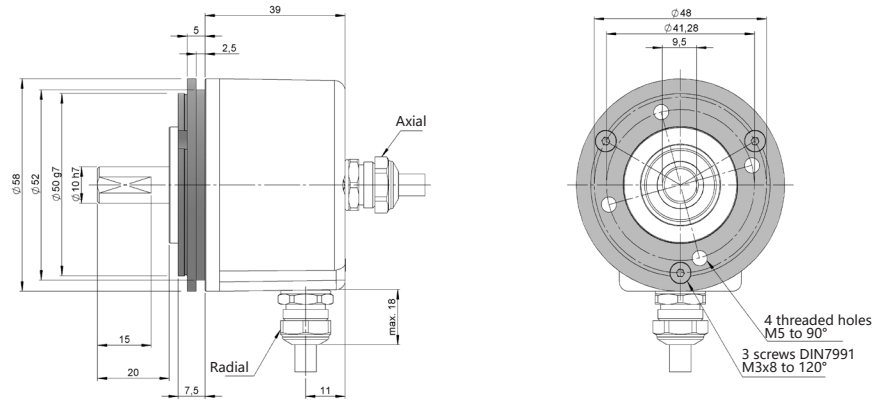

Flange 5
90.1005

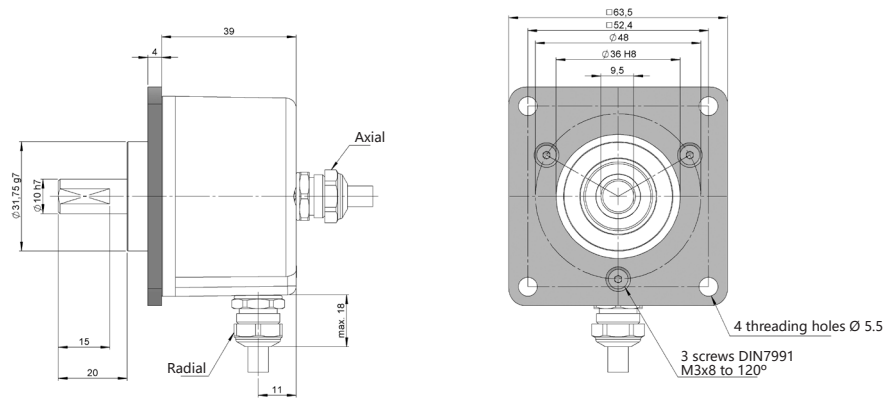

Flange 6
90.1006

